

# SERVICE INSTRUCTIONS

MERGENTHALER 31

Letterpress is letterperfect

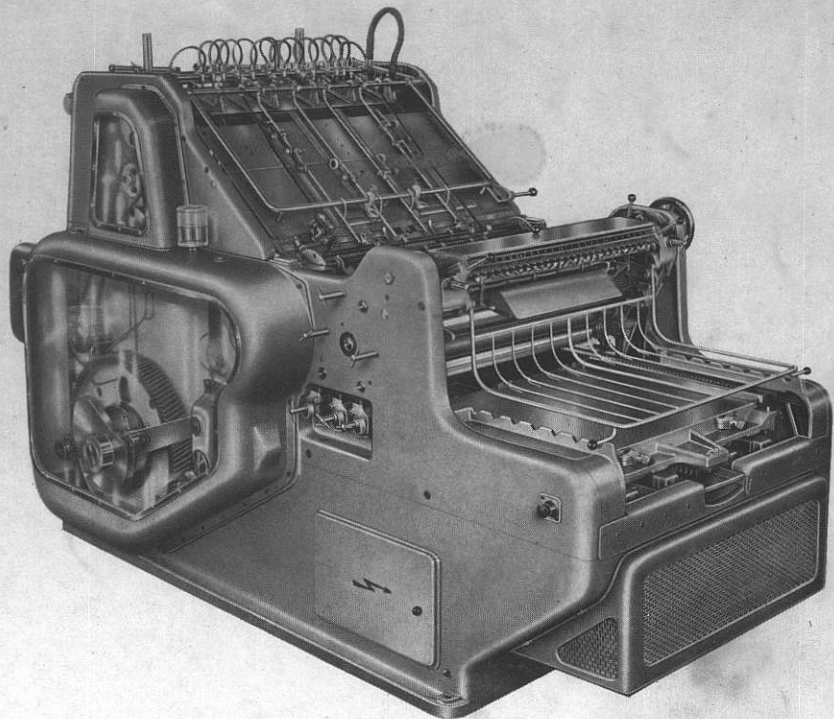

MERGENTHALER LINOTYPE CO.

PLATE N. 56968

CUSTOMER \_\_\_\_\_

CONTRACT N. \_\_\_\_\_

DATE \_\_\_\_\_

DATE OF SHIPMENT \_\_\_\_\_

I N D E X

Specifications . . . . .	page 2
Foreword . . . . .	» 3
Accessories and Equipment . . . . .	» 3
Lubrication . . . . .	» 5

**Press Operation**

Controls . . . . .	page 7
Feeder . . . . .	» 8
Feedboard . . . . .	» 10
Side pull guides . . . . .	» 11
Front drop guides . . . . .	» 12
Printing cylinder . . . . .	» 13
Bed and Chase . . . . .	» 14
Delivery . . . . .	» 14
Ink Fountain . . . . .	» 17
Ductor roller . . . . .	» 17
Distributing and form inking rollers . . . . .	» 18
Automatic wash-up . . . . .	» 19
Compressed air and suction systems . . . . .	» 19

**Periodical maintenance**

Tapes . . . . .	page 21
Drive belts . . . . .	» 23
Electric sheet detectors. Feed and delivery pile contacts . . . . .	» 23
Automatic cylinder lift . . . . .	» 23
Instructions for the electric equipment . . . . .	» 25
Instructions for the change of voltage and frequency . . . . .	» 25
Timing of feeder with press drive . . . . .	» 26
Feeder adjustment to paper size . . . . .	» 27
Feeder adjustment to paper type . . . . .	» 29
Feeder: troubles, their causes and how to correct . . . . .	» 31
Diagram of main controls . . . . .	» 33-34
Foundation diagram . . . . .	» 35
Overall dimensions and floor space diagrams . . . . .	» 36
Lubrication diagram . . . . .	» 37

SPECIFICATIONS

Designation . . . . .	MERGENTHALER 31
Maximum sheet . . . . .	22" × 31"
Minimum sheet . . . . .	10" × 7½"
Maximum printing area with standard chase . . . . .	21¼" × 30"
Maximum printing area with skeleton chase . . . . .	21¼" × 30⅝"
Maximum impressions per hour . . . . .	4,000 i.p.h.
Height of feed pile . . . . .	11¾"
Height of delivery pile . . . . .	21"
Drive motor . . . . .	5 HP
Air compressor motor . . . . .	2 HP
Overall dimensions (length × width × height) . . . . .	8'9" × 6' × 5'6"
Net weight, approx. . . . .	8,800 lbs
Gross weight, approx. . . . .	9,200 lbs
Packing volume of press shipped assembled . . . . .	388 cu. ft.

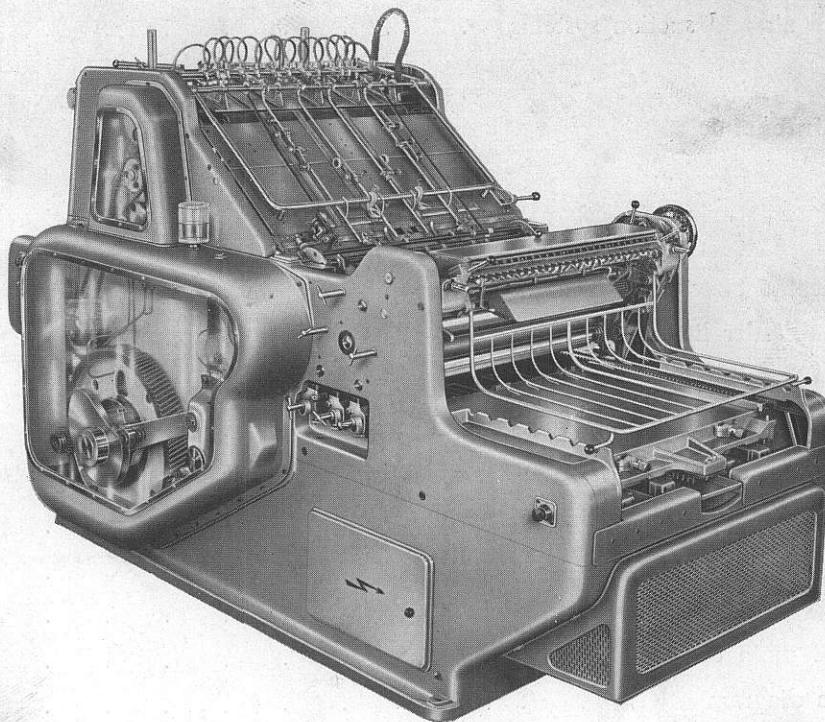

Weights, dimensions and constructional data may be changed without notice.

## FOREWORD

The front side is where the form is placed on the bed (ink fountain end).

The back is where the feed and delivery piles are located.

The right side, or operator's side, is where the controls are located.

The left side is the gears' side.

## ACCESSORIES AND EQUIPMENT

**Standard Accessories and Equipment.**

- 1 Service Instructions Book.
- 1 Spare Parts Book.
- 1 Set of electric wiring Diagrams.
- 1 Tool wall board.
- 1 Oil pump.
- 1 Oil gun.
- 1 7-8 mm. double-head spanner for hex-head screws.
- 1 7-9 mm. do.
- 1 10-12 mm. do.
- 1 14-17 mm. do.
- 1 19-22 mm. do.
- 1 24-27 mm. do.
- 1 4 mm. gauge spanner for Allens screws.
- 1 5 mm. gauge do.
- 1 6 mm. gauge do.
- 1 8 mm. gauge do.
- 1 10 mm. gauge do.
- 1 12 mm. gauge do.
- 1 14 mm. gauge do.
- 3 Hex. socket spanners, 14, 17, 22 gauge.
- 1  $\phi$  3 mm. pin wrench (double head).
- 1  $\phi$  4-4.5 mm. double head pin wrench.
- 1  $\phi$  7 mm. pin wrench (double head).
- 1 10 mm. wrench for grippers.
- 1 5  $\times$  0.5 mm. screwdriver.
- 1 8  $\times$  1 mm. screwdriver.
- 1 12  $\times$  1.2 mm. screwdriver.

- 1 Roundnose pliers for 10/25 mm. circlips.
- 1 Angle roundnose pliers for 10/25 mm. circlips.
- 4 9 × 5 mm. spare sucker connection tubes.
- 16 Rubber sucker caps for light papers.
- 16 Rubber sucker rims for cardboard.
- 4 Plastic feedboard tapes.
- 1 Spare plastic feedboard tape.
- 12 Delivery tapes (cotton).
- 1 5<sup>1</sup>/<sub>2</sub> yrd length of delivery tape (cotton) 1<sup>3</sup>/<sub>16</sub>" × 1<sup>1</sup>/<sub>16</sub>".
- 2 Feeler gauges for wash-up attachment.
- 2 Dividers for two-up.
- 2 Springs for light papers on pull guides (left and right).
- 1 Cylinder blanket and rod.
- 1 Form board.
- 1 Tin of paint.
- 1 3 yard length of wick for oil sumps.
- 6 Spare oil pressure fittings.
- 1 Grooved pulley for 4.000 impressions per hour.

Two sets of covered rollers - Tachometer - Delivery rack - Rotary, independent drive air compressor - Electrical equipment complete with motors and controls - Two two-up attachments - Two aluminum delivery boards - Automatic wash-up - Adjustable cylinder brush - Delivery and form lighting installations - Two chases - Three ink fountain dividers - Feed and delivery joggers - Two two-sheet calipers - Sheet counter - Two micro-adjustable automatic pull lay guides - Reloading feeder - Dry spray - Steel sheet strips, steel guides and adjustable pressure roller guides.

**Specialized Accessories upon request.**

## LUBRICATION

**Main drive mechanisms** and practically all gears are enclosed in a large casing on the left side of the press.

Lower mechanisms dip right into the oil at the bottom of the casing: the others are lubricated by an oil spray from a series of nozzles fed by a gear pump which draws oil from the bottom of the casing.

A similar system lubricates the two shaft bronze bushings, the counter crankshaft bronze bushing and the two flywheel shaft bushings.

A second small piston pump, also located in the casing on the left side of the press, with an independent glass vessel (No. 1, fig. 2) pressure oil lubricates the bed-ways and cylinder bushings.

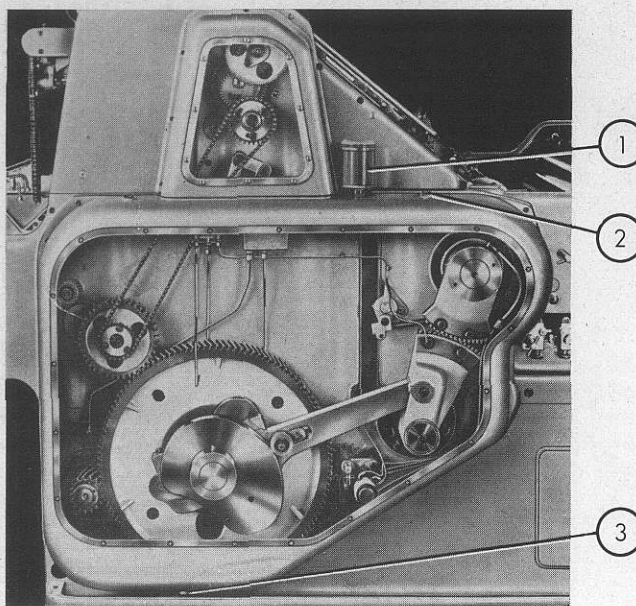

Fig. 2

The operator must accurately check:

- 1) **Oil level** through inspection hole. If level is lower than marked on inspection hole, add oil through upper hole after removing screw plug (No. 2, fig. 2).
- 2) **Regular Oil Flow** from oil nozzles by observing press operation through plastic cover (Fig. 2).
- 3) **Oil level** in transparent glass vessel of small piston oil pump on top of casting (No. 1, fig. 2).

The lubrication system should be cleaned and the oil changed after the first 1000 hours of operation and every 2000 hours afterwards.

To drain oil unscrew magnetic plug (No. 3, fig. 2) on lower hole at bottom of casing and carefully remove dirt and metallic fragments.

- 4) Clean bronze filter in the fitting on which the oil tank is fixed after every five or six refillings.
- Use only high-grade oil with characteristics similar to those specified on page 6.

Lubrication of all other parts (see diagram at page 37) should be done with grease guns and oilers carefully following these instructions:

- Always lubricate when press is idle (preferably with main switch off).
- Use high grade oil and grease; equivalent to the following types which we indicate as most suitable. If other brands are used make sure that they have similar characteristics.

- |   |  |
|---|--|
| <input type="radio"/> SHELL VITREA OIL 37<br><input type="checkbox"/> MOBIL VACTRA OIL HEAVY S.A.E. 30                | <i>Am. D.R. 10 #51</i><br>on bed sliders, gears and racks under the bed and for general lubrication with oilers, wick feed oil cups and holes. |
| <input type="checkbox"/> SHELL ALVANIA GR. EP 1<br><input type="checkbox"/> SOVAREX GREASE No. 1                      | <i>#150</i><br>for gears and racks except those under the bed.   |
| <input checked="" type="checkbox"/> SHELL ALVANIA GR. 1<br><input checked="" type="checkbox"/> MOBIL GREASE BRB No. 1 | <i>#150</i><br>in grease cups.   |

NOTE: When above oil brands are not available, use **oils**, viscosity 5,8-6,2 at 50°C, **greases** with dropping point A.S.T.M. 300-350.

*Never use regular motor oil as used in motor cars.*

For the small piston pump use oil used for general lubrication that is SHELL VITREA OIL 37 or MOBIL VACTRA OIL HEAVY.

A separate small feed tank is used for this pump as oil must be clean and free of impurities. The symbols shown by the side of each lubricant are also shown on the lubrication diagram (page 37) giving detailed instructions and specifying intervals between two successive lubrications.

**IMPORTANT: When the press operates an anti-offset powder sprayer, reduce lubrication intervals by 50%.**

Manual lubrication of points 2 and 12 shown on diagram (page 37) despite the adoption of the small piston oil pump is still advisable when:

- a) the press has remained idle for a long period;
- b) the oil level in the transparent tank does not lower with regularity;
- c) oil fails to fill up the small transparent tubes to the cylinder bushings.

**Lubrication is a factor of extreme importance particularly during the running-in period.**

The operator should give the greatest attention to lubrication and familiarize himself with all points requiring periodic attention as shown on lubrication diagram at page 37.

After lubricating turn the press by hand for a few rotations to make sure that oil has reached all various points then start the press at low speed for at least half an hour checking that no shaft or bearing is *warming up*.

Lubrication of air compressor is independent and should be taken care of in accordance with instructions attached to the unit.

## PRESS OPERATION

Before definitely taking over operation the press minder should familiarize himself with all the controls, using great caution. Main controls are:

1) **Brake lever** (No. 1, pages 33-34) with two positions:

Left: brake on;

Right: brake off, the press is released for operation.

2) **Switchboard** (No. 2, pages 33-34), including:

a) **AUTOMATIC STOP** tumbler switch for feedboard electric control, with two positions:

Left: off (electric control inoperative);

Right: on (electric control operative).

b) **MOTOR PUSH BUTTON SWITCH**, with two positions:

Push button switch turned to left for forward inching;

Push button switch turned to right for regular starting.

3) **Press stop push buttons.**

Two push buttons are placed to left on the rear and front side of the machine respectively.

The press can also be stopped by merely lifting the safety rack on the bed but in this case stopping is not instantaneous.

**CAUTION:** When the rack is lowered the press starts again.

4) **Speed control lever** (No. 2, pages 33-34).

Passing from position 1 to position 7 on the numbered plate, the press speed varies from a minimum of 600 i.p.h. to a maximum of 4,000 i.p.h.

To start press without feeding paper:

a) check that safety rack over the bed is lowered;

b) turn knob of « **MOTOR** » push button on « **CONTINUOUS** » position;

c) keep knob of « **AUTOMATIC STOP** » on « **OFF** » position to keep electric control inoperative;

d) move brake lever to the right;

e) gradually move speed control lever from position 1 to following positions.

To start press and feeding paper: make all operations mentioned above, then:

f) start air compressor by turning tumbler switch on (No. 3, pages 33-34);

g) push in feeder control (No. 14, pages 33-34);

h) when the first sheet reaches the end of the feedboard, switch the automatic electric control on.

« **REVERSE OPERATION** » should always be done manually turning the flywheel in the opposite direction to the arrow after disengaging the brake. (Brake lever to the right: No. 1, pages 33-34).

**FEEDER**

The MERGENTHALER 31 is equipped with an air controlled automatic forward suction feeder, consisting of:

- 1 pre-loading feeder board;
- 1 series of telescopic and spring actioned suckers;
- 1 movable air blower for sheet separation;
- 1 steady air blower for sheet separation;
- 1 feedboard with tapes and tension rollers;
- 2 side pull lay guides.

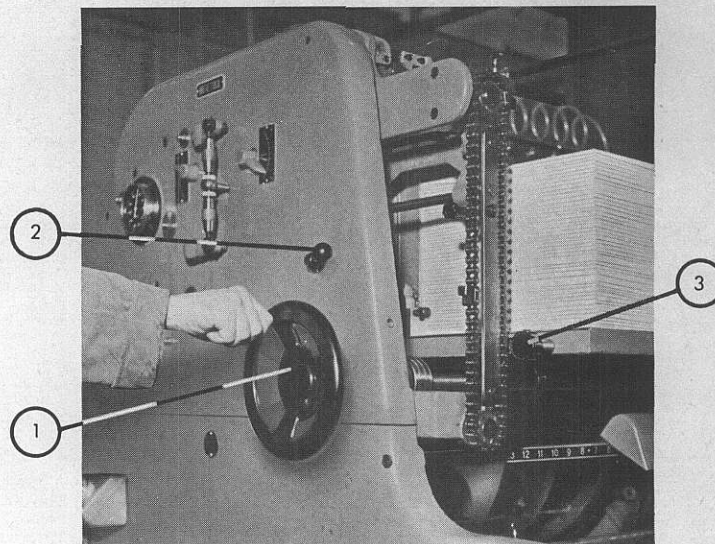

Fig. 3

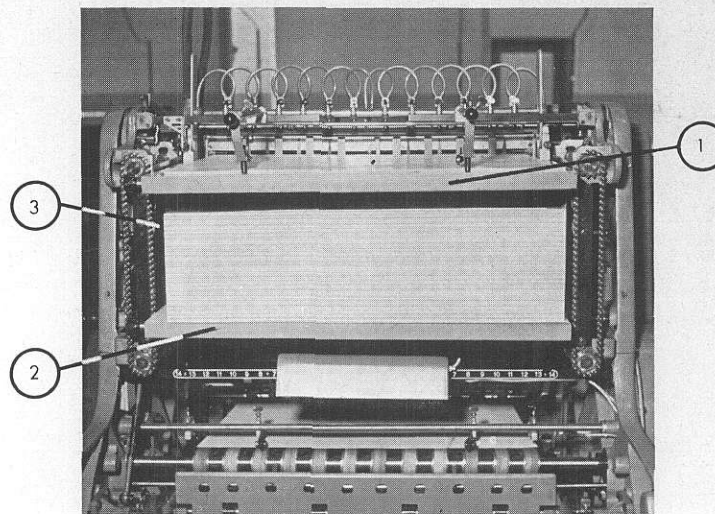

Fig. 4

**The pre-loading feeder.** - This permits the preparation of a new pile while the press is in operation reducing down time, when the first stock is exhausted, to a few seconds. Two boards are provided for this purpose: an upper board (No. 1, fig. 4) with electromagnetic automatic lift (No. 3, fig. 4) holding the sheets ready for printing, and a lower board (No. 2, fig. 4) resting on special supports on which the reload pile is prepared.

A set of chains lifts the upper board. When the sheets of the latter are running short, the chains automatically lift the lower board.

The empty table should then be removed and the new pile is ready for printing. Manual lifting of the board is effected by means of the handwheel (No. 1, fig. 3) after disengaging the ratchet with lever (No. 2, fig. 3).

The two side stackers have been made collapsible so that they can be placed in position even when there is little room between the two boards.

The arrangement includes a knob (No. 3, fig. 3) for micrometer adjustment of pile lateral position in relation to side guides.

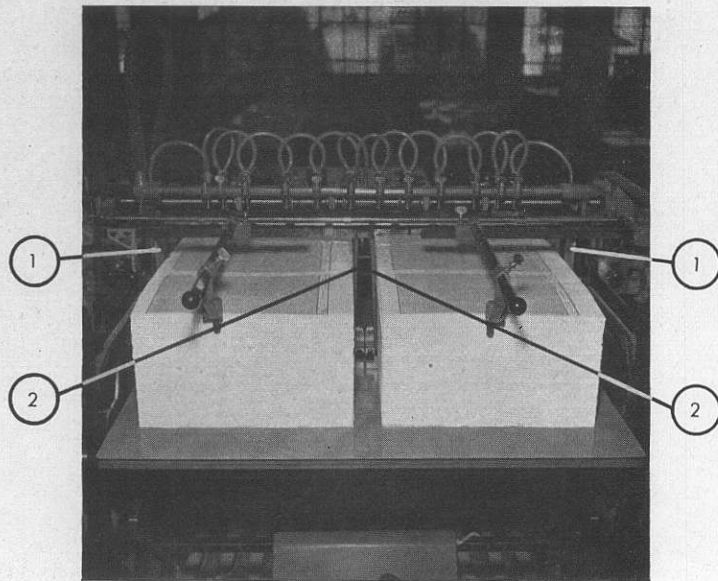

Fig. 5

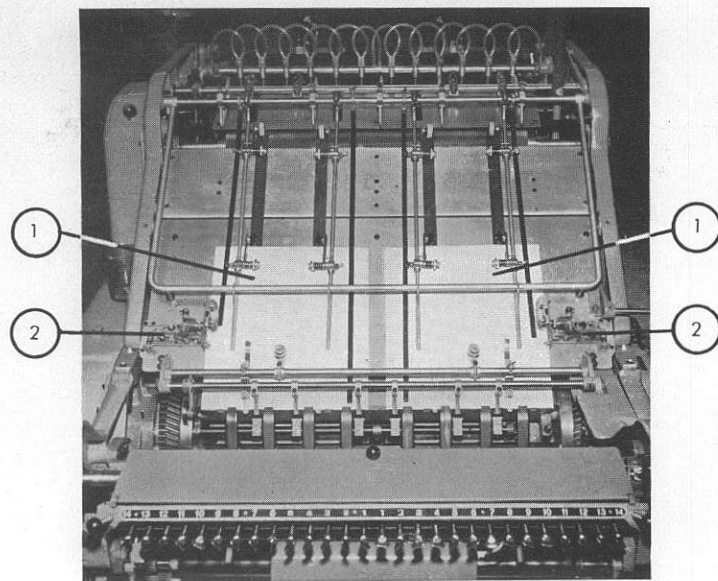

Fig. 6

Three inch graduated reference lines, one on the feedboard, one on the feeder board and one on the chase, facilitate adjustment of paper travel through the press. Also marked on the chase are the position of the cylinder and drum grippers and the space they take up.

### Paper travel.

Drawings at pages 27, 28, 29 and 30, show the main adjustments to be made on the paper feeder for varying types of papers, from tissue to light cardboard. They also list the most common troubles, their causes and remedies at page 31. Positions of controls to be operated for all these adjustments are shown at pages 33-34.

The press permits simultaneous printing of two small sizes (fig. 5 and 6). In that case both right and left side pull guides must be used (No. 2, fig. 6). Two piles of even height are placed on the feeder board and held in position by two vertical stackers (No. 1 and 2, fig. 5).

### FEEDBOARD

The sheet travels down this board, main components of which are:

— **Four conveyor tapes:** already placed to take any size but they can nevertheless be shifted sideways by means of four chrome plated handles (No. 1, fig. 8) which are accessible from the back of the machine over the drum.

To lift the feedboard, first raise the frame (No. 3, fig. 7) which supports the guide rollers, then grip the handle, raise the feedboard and lock it up with the lock provided for this purpose (No. 4, fig. 7).

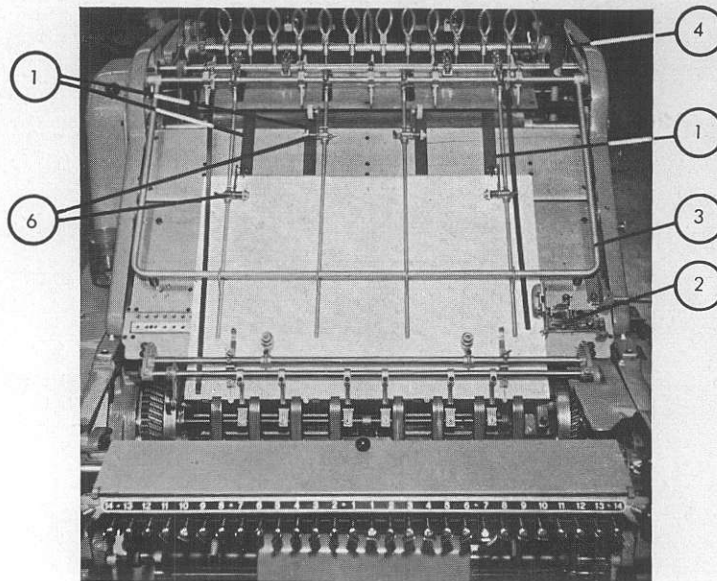

Fig. 7

— **Four tension rollers** of which only two need to operate for each size. For adjustment of tension rollers on paper see drawing, page 28.

All these rollers can be simultaneously raised by raising the tension roller frame.

— **Eight guide rollers** which can be moved along four rods supported by the feedboard hinged frame.

To center the rollers with the tape centre, move the support rods sideways after loosening the locking screws. To mount the roller supports on the rods, introduce them from the free end of the rods after the frame has been raised; then lock them in position by means of the screws provided for this purpose.

For adjustment of rollers to paper see drawing at page 28.

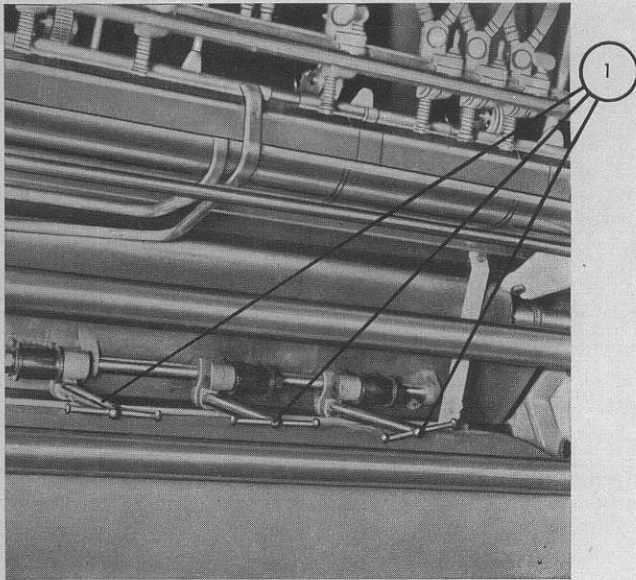

Fig. 8

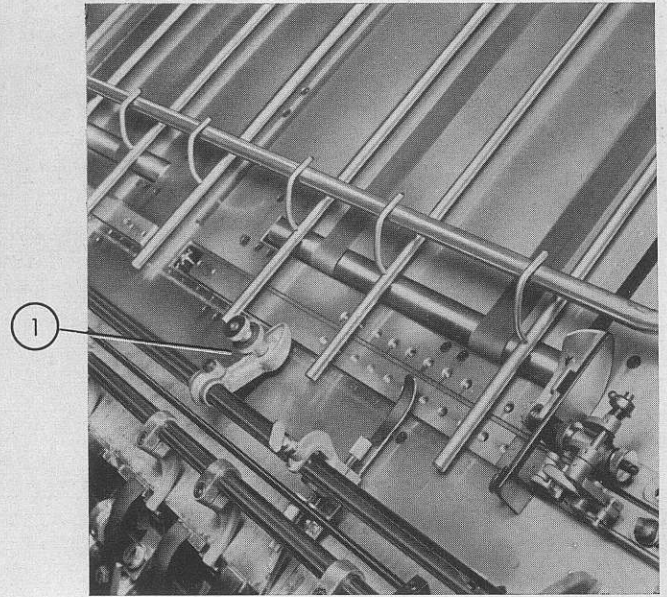

Fig. 9

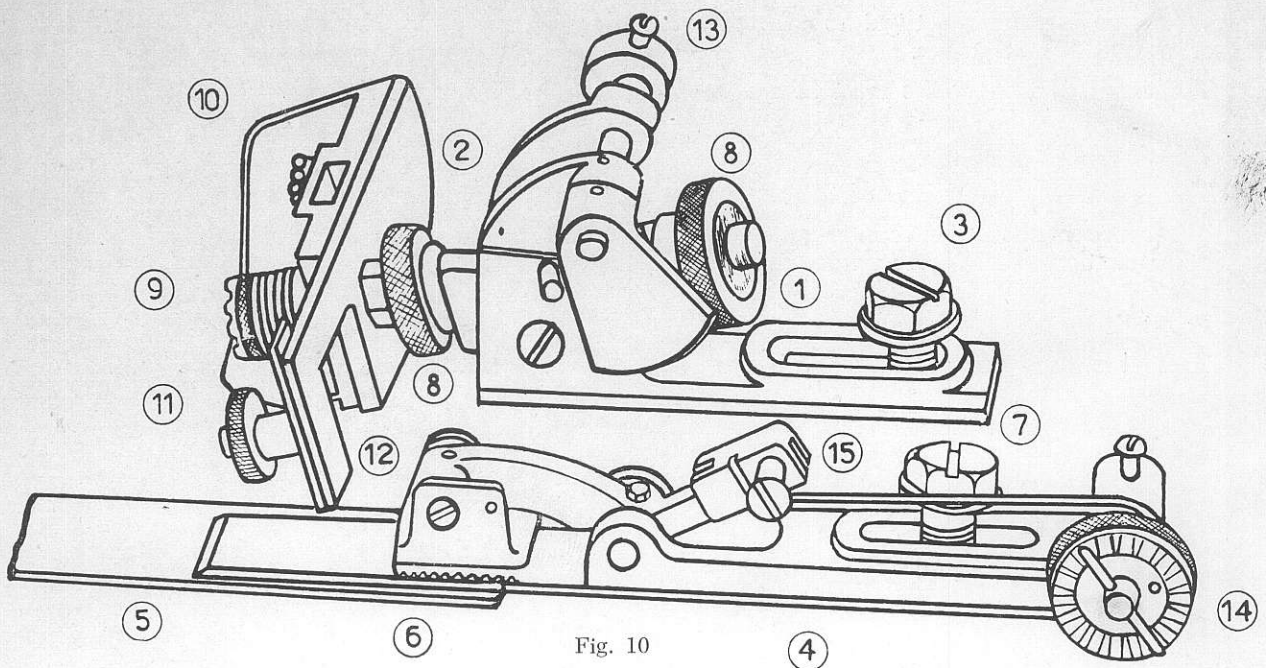

Fig. 10

**AUTOMATIC SIDE PULL GUIDES** (Stroke  $1\frac{1}{16}$ ").

Two guides are supplied: one for the near and the other for the far side of the press. They consist of:

Adjustable pull guide, resting on a support to be fixed to the feedboard.

Adjustable pressure hammer, resting on a support to be fixed on the movable slideways.

For accurate adjustment proceed as follows:

- 1) Set press running slowly, bring one sheet up **to front guides** and stop.
- 2) Place stationary unit (1) on the feedboard, align it and place its lateral edge in the special groove in the feedboard. Place inner side (2) of side guide at about  $\frac{3}{8}$ " from side edge of sheet. Tighten bolt (3) in hole nearest to center of slot.
- 3) Place movable unit (4) on slider (5), pass it through opening of side guide (2) and move it forward on slider until hammer (6) is still up but **just about** to snap on sheet, then block movable unit on slider by tightening up bolt (7) in hole nearest to center of slot.
- 4) When the press is started again, the movable unit, drawn by slider (5) must still move slightly forward to allow hammer to drop, then reverses immediately and pulls the sheet against side guide (2).
- 5) Adjustment. Nuts (8) are for slight variation to position of the side guide (2). Knob (9) is for adjusting space between guide (10) and board, according to thickness and quality of paper.

To operate, lightly press nut against the spring, turn and release. Plate (12) is locked in position by means of knob (11) after the plate has been brought in contact with the board. Ring (13) regulates rocker lever return spring pressure.

Knob (14) regulates spring (15), transmitting to the hammer the pressure required for carrying on the paper. Spring (15) is supplied with the press in two types for each guide: one for normal and heavy papers and one for light papers.

**The two two-sheet calipers** must be fitted to the cross rod of the feedboard and adjusted in accordance with instructions at page 31.

On the same rod are also mounted the **electric contacts** for the paper travel control, which must be aligned with two of the four steel paper guides placed under the feedboard, movable on their supports and removable from the end of the latter.

When moving the sheet guides take care that they do not collide with the cylinder grippers or with the front guides.

The two ball shoe guides must be mounted on the roller frame, as shown in fig. 9.

#### Counter-guides.

They guide the front edge of the sheet up to the front drop guides.

The space beneath the counter-guides may be varied by adjusting the eccentric pin of the roller on the control lever on the left side of the cylinder.

#### Front drop guides.

These are fixed on one of the cylinder rods by knurled slotted head screws (No. 3, fig. 11).

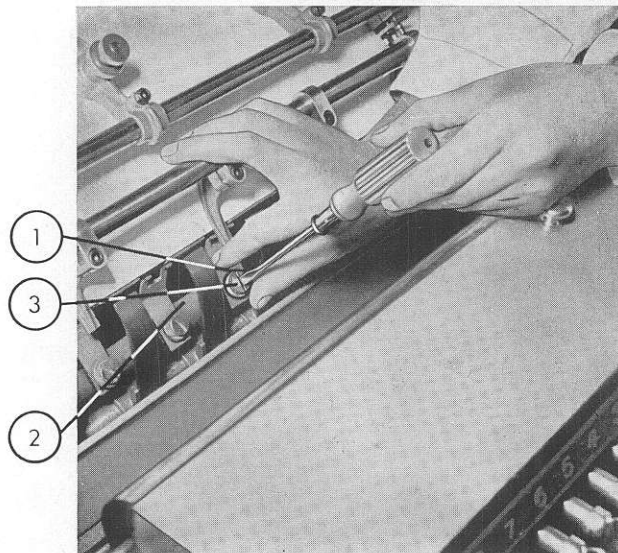

Fig. 11

The position of every guide can be varied by loosening screw (No. 3) and then rotating knurled nut 1 (fig. 11). There is an index on the rod to serve as reference.

As a rule it is best to use two guides only leaving the others slightly removed from the edge of the sheet. The guides can be dropped back by completely rotating their supporting rod.

This becomes necessary when replacing the cylinder packing.

**IMPORTANT! Take care to return the guides in working position before starting the press!**

The front cylinder guides and the side margin of the automatic side pull guide must be adjusted so as to be perfectly perpendicular. To check use a perfectly squared sheet and make sure the two adjacent edges rest exactly on the side front guides.

### PRINTING CYLINDER

**Cylinder pressure** on bed bearers is accurately gauged at the factory to suit all types of work. The customer therefore should never change the eccentric bushing adjustment.

**Lifting:** move handle 22, page 34, from horizontal to vertical.

**Packing:** the plate on the right shoulder specifies the cylinder packing thickness, including the sheet to be printed (.059").

Careful cylinder packing is essential to good printing.

**To remove cylinder packing** proceed as follows:

- raise the feedboard;
- lift the cylinder;
- turn the press by hand until the tension rods become accessible;
- insert a pin wrench in their holes, turn slightly to release the stop pawls. The cylinder packing can now be removed from the rods;
- holding the packing up, turn the cylinder backwards until open grippers are visible, then drop back the guides, loosen the screw on the cylinder packing clamp sufficiently to free the packing.

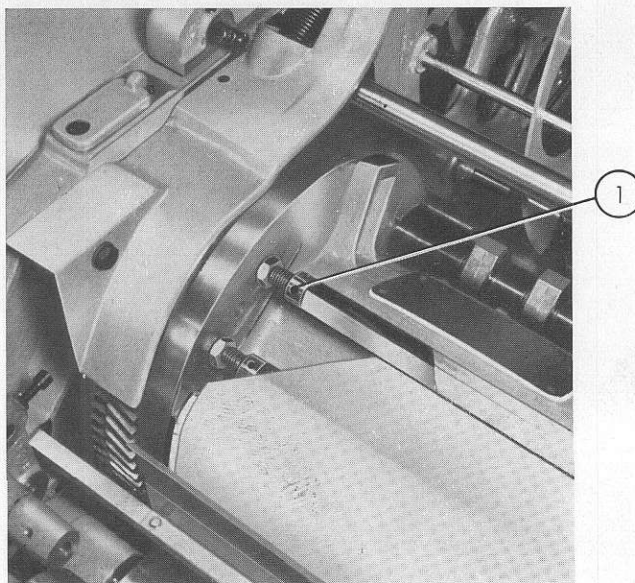

Fig. 12

To mount new packing reverse the above operations.

**Grippers:** Are self adjusting and need no adjustment.

**Cylinder brush:** Serves to keep the sheet sufficiently close to the cylinder right before the printing phase. Can be adjusted by loosening the hex-head screw which locks the operating knob 32, page 34, and turning the latter to the left for greater pressure or vice-versa. To take down the cylinder brush remove locking screw and slip off both knob and brush.

**Packing tension bar** can be taken down after loosening coupling 1 (fig. 12).

### BED AND CHASE

After moving the bed to front dead center and raising the rack guard 1 (fig. 13), place the chase on the bed with marked edge towards the cylinder making sure that the lower notch slides over the centering button 2 (fig. 13) protruding from the bed.

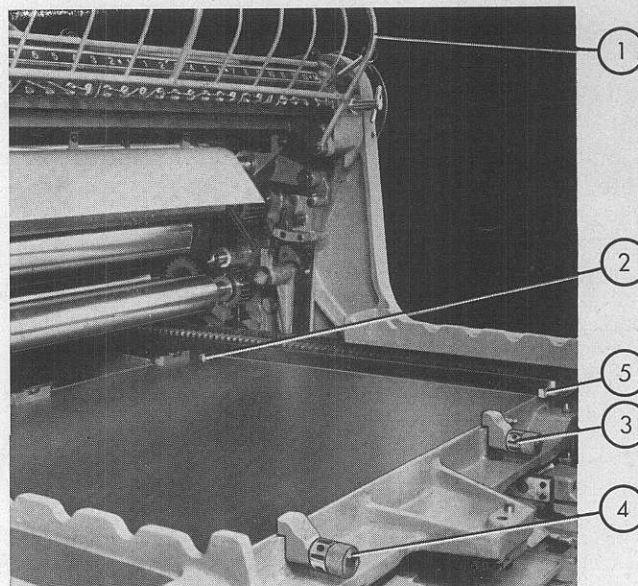

Fig. 13

Lock it in position using a pin wrench to tighten chase lugs 3 and 4 (fig. 13). A safety catch on the bed right bearer 5 (fig. 13) prevents the chase from slipping off in case the clamps are inadvertently left loose.

The press does not start until **the rack guard is lowered**: before lowering it and restarting the press **see that the chase is securely locked on the bed and that no tools or other items have been left in the press.**

**Lighting:** an electric light and switch are located on the front side of the press, right under the ink-fountain.

### DELIVERY

Delivery of the printed sheet is achieved by the combined action of a large diameter sheet turning drum and of conveyor tapes, in three stages:

- 1) The sheet stops in a vertical position, its tail-end well clear of the form, even with the largest sizes.
- 2) The sheet is overturned and laid, printed side up, on the conveyor tapes.
- 3) The sheet is slowly conveyed along and delivered to the delivery pile while a blower system sets up an air cushion on which the sheet descends without smearing the previously delivered sheet.

The sheet turning drum has three series of independent spring grippers 3 (fig. 14) accurately adjusted at the factory to suit any type and thickness of paper. Each gripper rod is provided with a hole in which a tommy bar is inserted to open all grippers simultaneously.

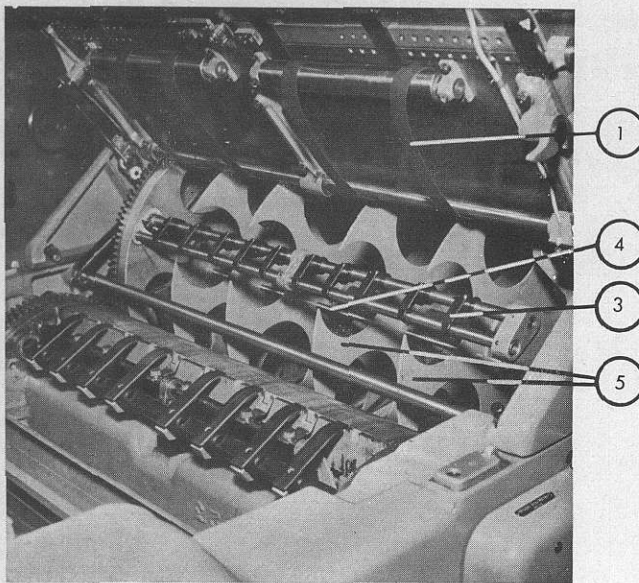

Fig. 14

The sheet turning drum also has three blower tubes 4 (fig. 14) to facilitate overturning of the sheet with every type and thickness of paper.

Blower action can be adjusted by operating knob 18 (page 34). The four supporting discs 5 (fig. 14) can be moved sideways by pressing the hub near the turning drum shaft to suit printing or size requirements.

**Tapes.** The 12 delivery tapes travel at uniform speed and need no adjustment when changing size or paper.

**Delivery blowers.** To adjust air blast to type of paper operate knob 17 (page 34).

**Delivery board** equipped with:

- **automatic lowering mechanism** with electromagnetic control, synchronized with the feeder stock pile lifting unit;

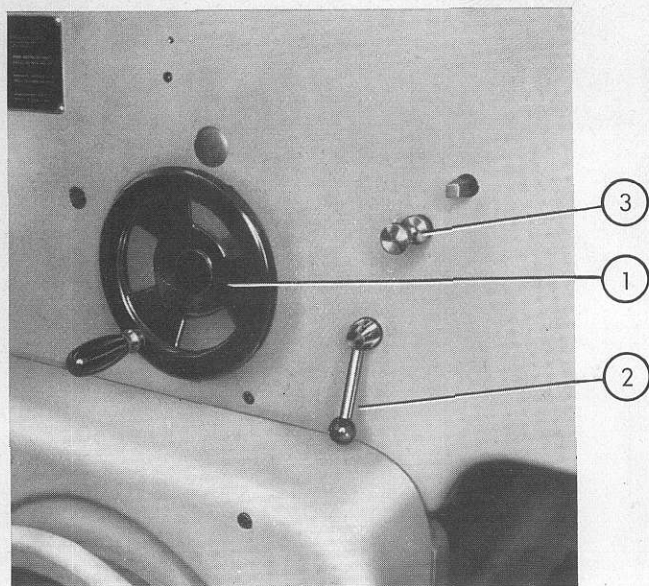

Fig. 15

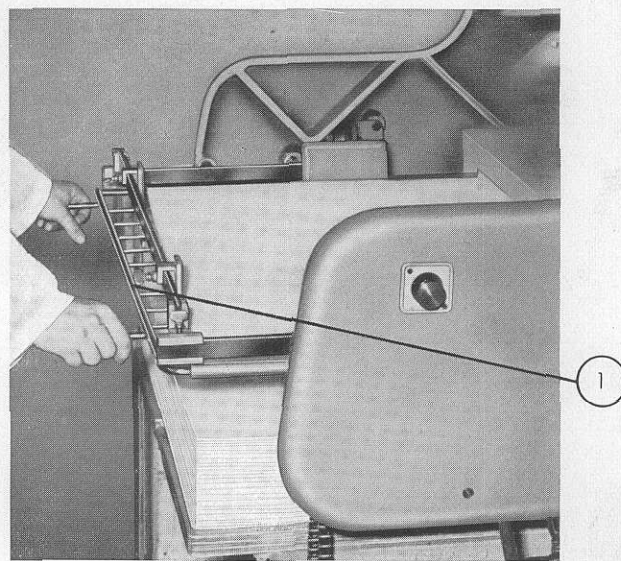

Fig. 16

- **manual raising and lowering mechanism** operated by handwheel 1 (fig. 15) after cutting out automatic control by operating handle 2 (fig. 15) to disengage drive pawl;
- **continuous delivery rack 1** (fig. 16) to receive printed sheets while delivery board is being emptied;
- **three-sided jogging** with stroke adjustable from  $\frac{3}{8}$ " down to zero by operating knurled-head set screw 3 (fig. 15) and check nut.

To adjust the two movable side joggers to width of paper, slide shank along movable guides after loosening winged head screw. Make this adjustment when movable guides supporting jogger shank are at inner dead centre (towards paper pile). Paper size may require changing the position of the two lateral joggers: as the shank is not in the centre of the jogger plate, it may sometime be convenient to interchange the two joggers to suit paper size. To do this slide each shank off its movable guide and fit it on the opposite movable guide.

**IMPORTANT! Make adjustment of side joggers when movable guides reach nearest point to paper pile.**

- **two front dividers** supported by a traverse rod on two small bearings which slide on two fixed side rods.

Adjustment to paper length is made by moving the traverse rod and then blocking the two supports.

Adjustment to paper width is made by moving the dividers on the rod to desired position and then locking them.

When printing two-up two special inner dividers can be fixed on the traverse rod.

- the delivery pile (height  $21\frac{3}{4}$ "") can be removed complete on the delivery board with castors, after unhooking the suspension chains, when it reaches floor level. One of the chain connection traverses sets up an electrical contact when the delivery board reaches bottom and automatically stops the press.
- **two sheet roller guides.** These rollers 1 (fig. 17), are adjustable to size of sheet on the traverse rod located above the tapes.
- **two electrical contacts.** These contacts 3 (fig. 17), are movable and should be set to suit size of sheet: they operate when the sheet delivery is irregular and trip the press.
- **Lighting.** A lamp and switch are located right over the delivery unit 4 (fig. 17).

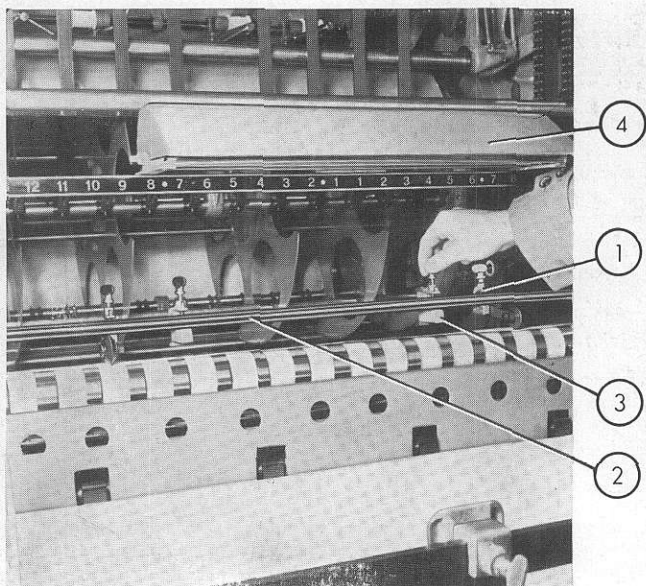

Fig. 17

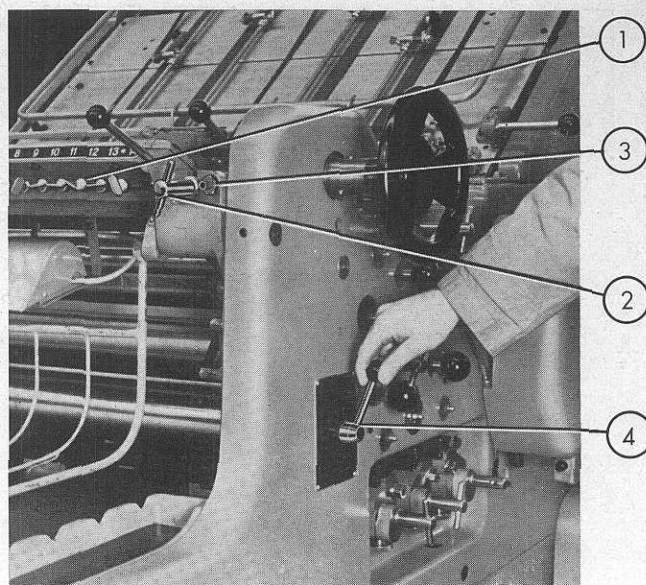

Fig. 18

**Anti-offset sprayer.** The left jogger slide is equipped with a connection for the sprayer control while two holes on the shoulder are provided for the spray unit clamp.

### INK-FOUNTAIN

#### Fountain blade adjustment.

Loosen all adjusting set screws 1 (fig. 18) so that they do not press down on blade. Check uniform distance between blade and roller by running a .004" gauge along the whole length. It may be necessary to adjust the position of the entire ink-fountain unit to the roller in order to obtain this exact distance.

To do this:

- a) loosen the two wing nuts 2 (fig. 18) which lock the ink-fountain;
- b) adjust set screws and nuts located on the ink-fountain ridges next to the wing nuts 3 (fig. 18);
- c) thoroughly tighten wing nuts 3 (fig. 18);
- d) adjust fountain blade contact with roller at different points by means of pressure keys 1 (fig. 18).

### DUCTOR ROLLER

**The ductor roller can operate** in three different ways (No. 4, fig. 18):

- a) the ductor roller feeds ink only with the cylinder on impression. With the cylinder raised the ductor roller does not feed and acts only as distributing roller;
- b) the ductor roller does not feed ink;
- c) the ductor roller feeds ink both with cylinder on impression or raised. Feed control handle is moved to the three position shown on the plate beneath (No. 26, page 34) for the above described operations.

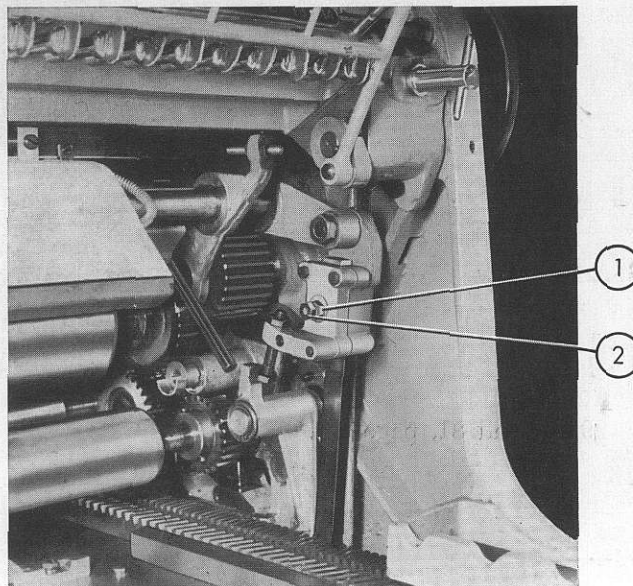

Fig. 19

#### Adjustment.

The weight of the ductor roller is balanced by a spring. It contacts the fountain and the vibrating rollers with even pressure controlled by means of a sliding arrangement (fig. 19)

operating automatically as soon as the ductor roller contacts the other two rollers. Contact pressure can be adjusted by regulating the screw (No. 1 and 2, fig. 19) of the slide shoe on the tie-rod inside the right shoulder. When making this adjustment do not lock the screw too tight to avoid excessive contact pressure, harmful to good distribution.

**To remove.**

Holding the roller with your left hand pull the bakelite knob on ductor roller right journal box outwards: tilt roller slightly and it will slip easily off the other journal box (fig. 20).

**DISTRIBUTING AND FORM INKING ROLLERS**

**Removal.**

Of the **distributing** rollers the three intermediate rollers can be removed with an operation similar to that for the removal of the ductor roller, by pulling out the bakelite knob 27 (page 34).

These rollers and the ductor roller are interchangeable.

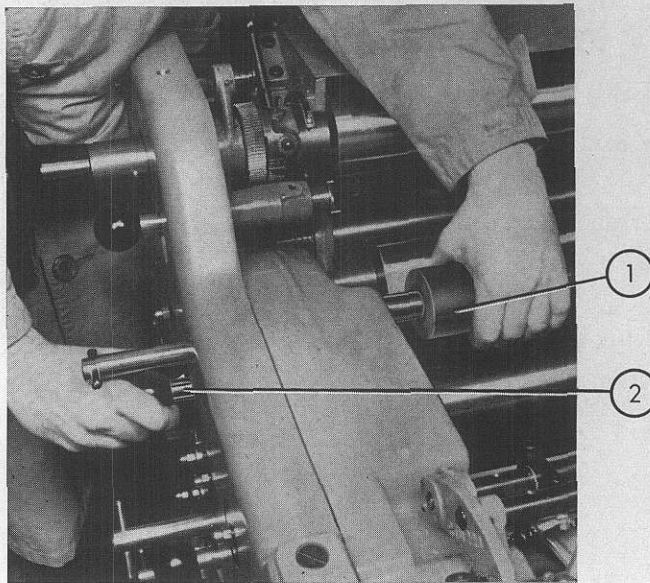

Fig. 20

To take down the **form inking rollers** loosen wing nuts 2 (fig. 21) which lock the three roller journal boxes on the right side of the press, move spacers 3 (fig. 21) to key shank, pull out journal boxes and let them turn downwards. Rollers can now be easily removed, also from the journal boxes on the left hand side without removing the latter.

**To adjust** (see No. 29, 30 and 31, page 34).

Contact adjustment of rubber **covered distributing roller** with steel vibrating rollers is made by turning the journal boxes which are then locked in position by wing nut 28 (page 34).

**To adjust form inking rollers:** proceed as follows:

- a) check contact with printing form: loosen hex-head locknut 1 (fig. 22) and check level of each roller by adjusting lower knurled nut 2 (fig. 22).
- b) Check contact with steel vibrating rollers: loosen wing nuts and adjust cap-screws which limit horizontal displacement of roller journal boxes.

**Cleaning the ink fountain.** Can be easily carried out by overturning the ink fountain after loosening and raising the two locking keys (No. 25, page 34).

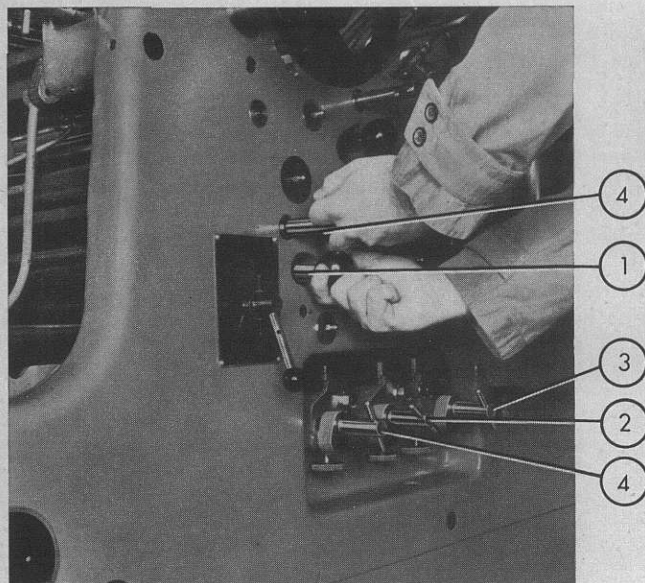

Fig. 21

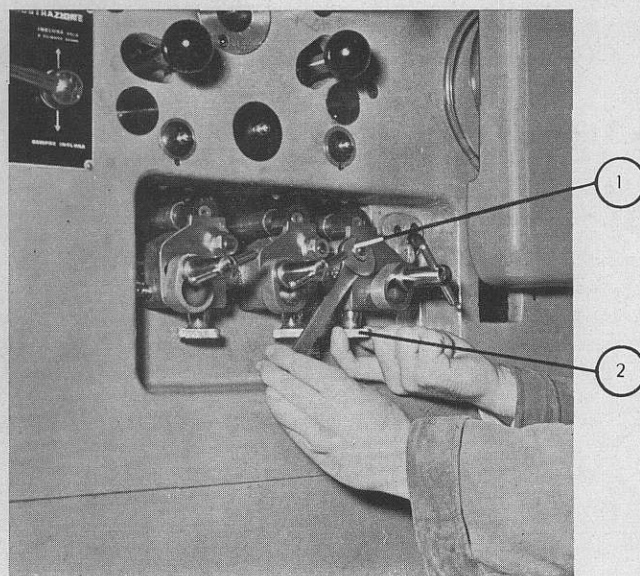

Fig. 22

**Fountain roller rotation adjustment.** By turning lever 24 (page 34) towards the printing cylinder the fountain roller intermittent rotating action is increased allowing more ink delivery per impression. By turning the same lever in the opposite direction ink feeding is gradually reduced until completely cut off. A graduated scale on the side plate of the ink fountain shows lever position.

**Ink fountain dividers.** There are three lead dividers to be placed in the ink fountain when the inked area is to be limited.

**IMPORTANT!** - Before starting the press make sure that all locknuts and keys of distributing and form inking rollers have been thoroughly tightened.

#### AUTOMATIC WASH-UP

The roller cleaner is embodied in the press for the purpose of cleaning all rollers and the form. The roller wash-up consists of a sludge basin in which a phosphor bronze scraper is located. The wash-up may assume two positions (fig. 23):

- 1) spaced from the vibrating roller during normal operation of the press;
- 2) in contact with the vibrating roller during wash-up operation.

To operate the wash-up proceed as follows:

- a) rotate the wash-up towards the vibrating roller until it snaps in. In this position the bronze scraper should contact the roller;
- b) start the press and drip the cleaning fluid on the distributing rollers;
- c) after washing-up empty sludge basin.

#### COMPRESSED AIR AND SUCTION SYSTEMS

Includes:

- a) a suction and force type rotary pump with independent drive;
- b) a distribution unit located inside the right hand shoulder of the feeder for sending air flow to the feeder blowers, delivery blowers and feeder suckers;

- c) a distribution unit located on the right hand side of the press for sending air flow to the blowers of the sheet turning drum;
- d) tubes connecting the various distribution units to the pump;
- e) tubes connecting the various distribution units to the suckers and blowers;
- f) tube connecting the pump to the anti-offset spray, when the press is equipped with a powder sprayer.

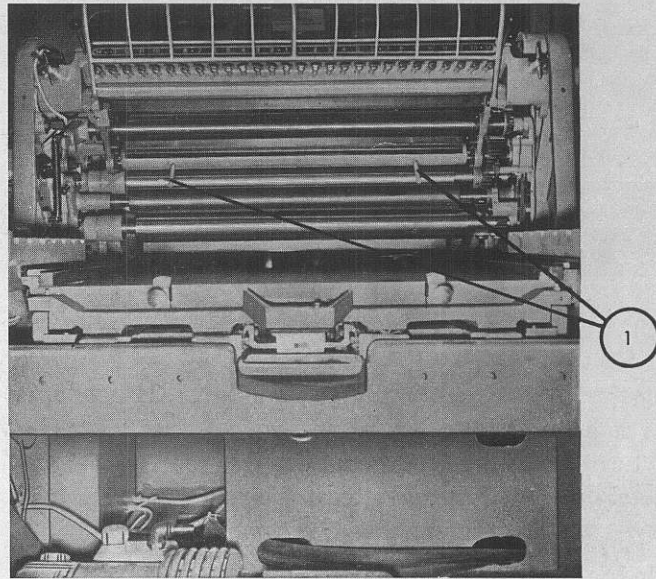

Fig. 23

## PERIODICAL MAINTENANCE

## TAPES

Two types of tapes are used on the MERGENTHALER 31:

- plastic tapes on the feeder;
- cotton tapes on the delivery.

**Feeder.**

Plastic tapes make sheet transfer regular and smooth and can be used for a long time without replacement. When replacement becomes necessary the joint of the new tapes must be perfectly made without gaps or roughness that may interfere with the sheet. Tapes are prepared for joining as follows:

- 1) Cut tape at required length.
- 2) Check exact length by trying tapes on press.
- 3) Fix the surfacing instrument 1 (fig. A) on the edge of a table.
- 4) Fix tape to plate 2 (fig. A).
- 5) Insert pin 3 (fig. A) of plate in corresponding coupling 4 (fig. A).
- 6) Rotate disc 1 (fig. A) gently pressing with your hand the plate 2 (fig. A) until tape end is properly surfaced and shaped.
- 7) Insert prepared end of tapes in feeder. To facilitate the operations that follow keep the feedboard up by inserting a piece of wood between feedboard and frame shoulder.

**IMPORTANT!** When the tape is placed on the feeder its smooth side must be on the outside, that is in contact with the sheet and its upper end with its scraped and shaped side facing the feedboard. Therefore preparation of tape ends must be carried out keeping in mind their final position!

- 8) Raise upper plate 5 (fig. B), switch on the joining unit and wait about twenty minutes.
- 9) Lift the two steel clamps 1 (fig. B) fitted on the lower plate.
- 10) Place one end of the tape, with its scraped side up, in the centre of the lower plate and lower steel clamp to hold it in position.
- 11) Place the other tape end with its scraped side down on the previously fixed end making sure that the two tape ends are perfectly aligned and well in contact. Lower second steel clamp.
- 12) Lifting the extreme part of the upper end, use special glue to join the two ends. See that the tapes remain aligned: gently press with your finger the tape ends to ensure complete adhesion.
- 13) Lower lined upper plate 5 (fig. B): adjust screw 3 (fig. B) of pressure handle 4 (fig. B) to obtain suitable moderate pressure.
- 14) Wait 6-8 minutes.
- 15) After this period joints are completed. Open the press and wipe out excess of glue with a damp cloth. The tape is now ready for use.

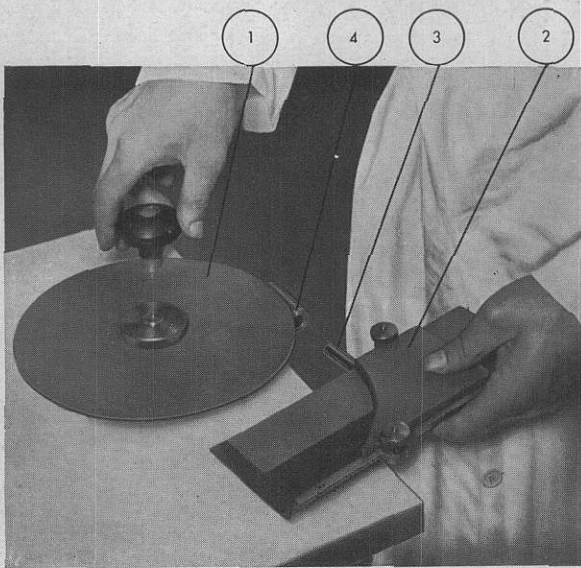

Fig. A

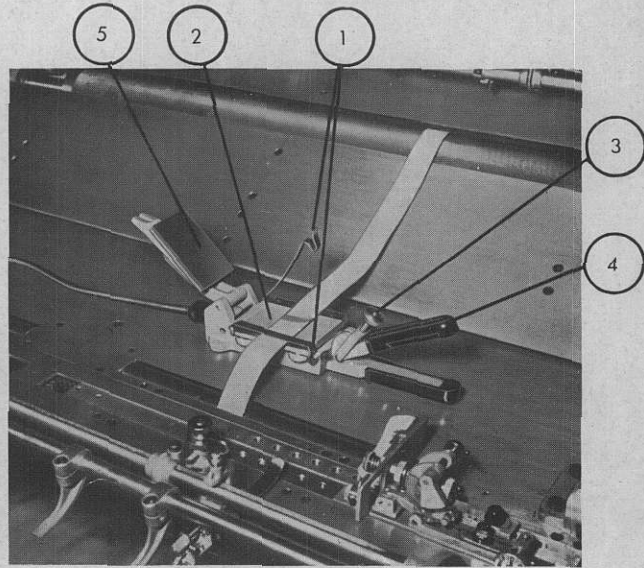
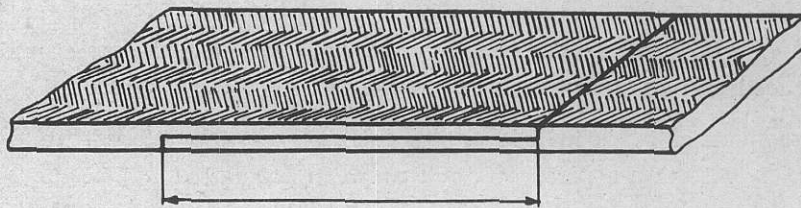

Fig. B

**Delivery.**

Delivery tapes also must have perfectly made joints. They can be stuck and joined outside the machine and fitted to the same after the joints have been made.



To mount them proceed as follows:

- a) loosen the tape stretching rod by means of the nut locking the supporting lever inside the right hand shoulder (fig. 24);

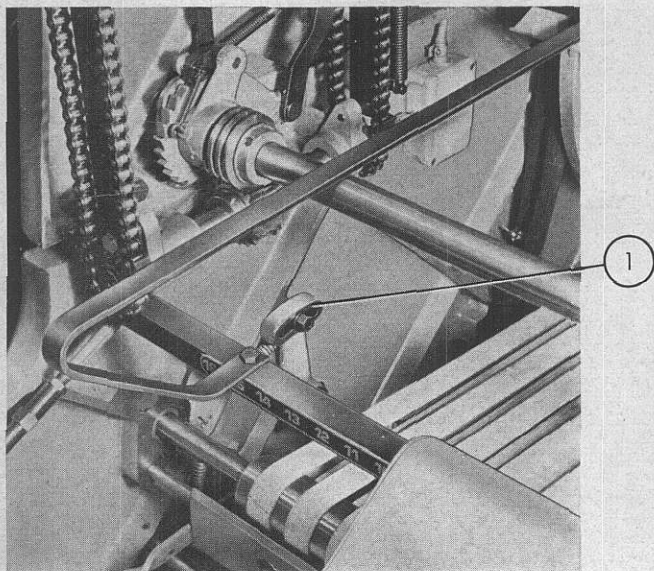

Fig. 24

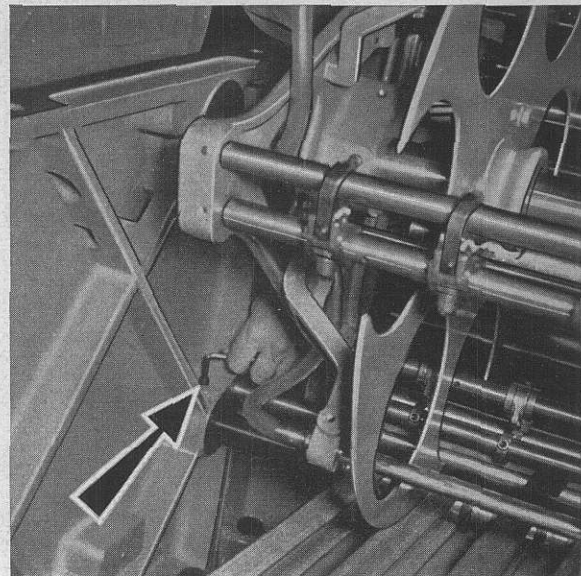

Fig. 25

- b) remove locking screw of the forward roller pin inside the right hand shoulder (fig. 25);
- c) pull out the roller pin and remove the forward tape roller (No. 1, fig. 26);
- d) loosen shoulder ring locking screw fitted to the tape drive shaft inside the left hand shoulder, and push this shaft towards the left hand side of the machine until it is withdrawn from the bushing on the right hand shoulder (fig. 27);
- e) fit new tapes to both shafts;
- f) repeat in reverse operations from d) to a).

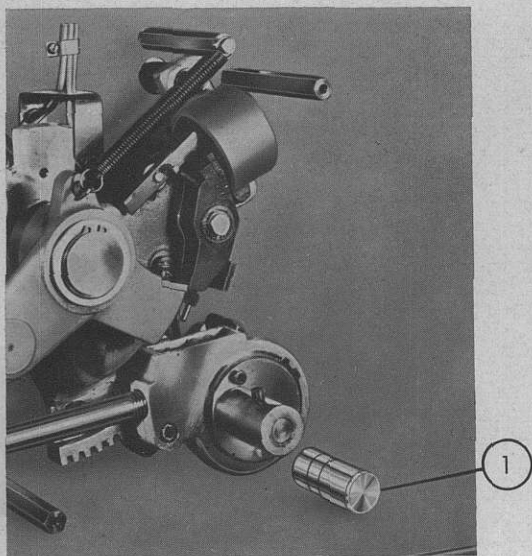

Fig. 26

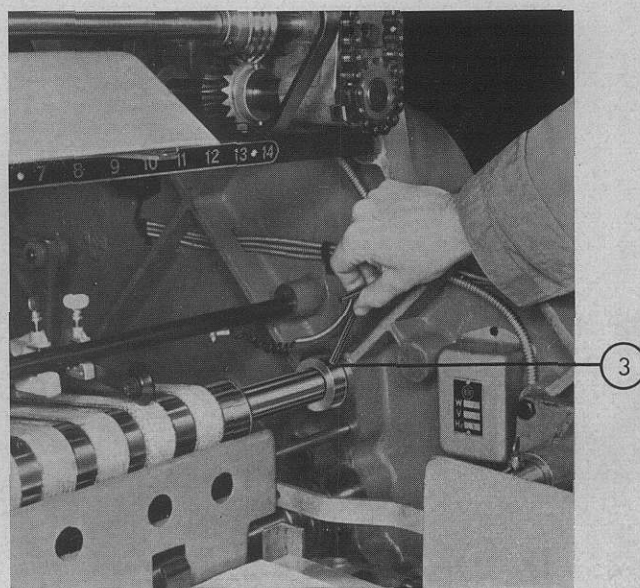

Fig. 27

#### Drive belts.

In the course of time V-belts may become slack. Drive motor belt tension can be adjusted by means of the screw on the rear motor supporting rail after removing the flywheel guard.

#### Electrical sheet detectors. Feed and delivery pile contacts.

Cleanliness has the greatest importance for satisfactory operation of press. For repairs and up-keep employ skilled personnel only.

Before starting a new run clean carefully the electrical sheet detectors and the feed and delivery pile contacts.

#### AUTOMATIC CYLINDER LIFT

The press is equipped with automatic cylinder on impression and off impression control. Before starting the press the operator must put the « automatic control » switch to the « ON » position.

When the first sheet arrives at the front drop guides it actuates the automatic control and the cylinder goes on impression and begins to print.

As long as sheets continue to arrive and are regularly fed into the press the cylinder remains on impression and continues to print.

If a sheet fails to arrive or arrives at an angle, the automatic control trips the press and the cylinder goes off impression.

To restart the press after a stop the press minder disengages the brake lever and the press starts running with the cylinder off impression.

The sheet itself arriving at the front guides actuates the automatic control and the cylinder goes on impression.

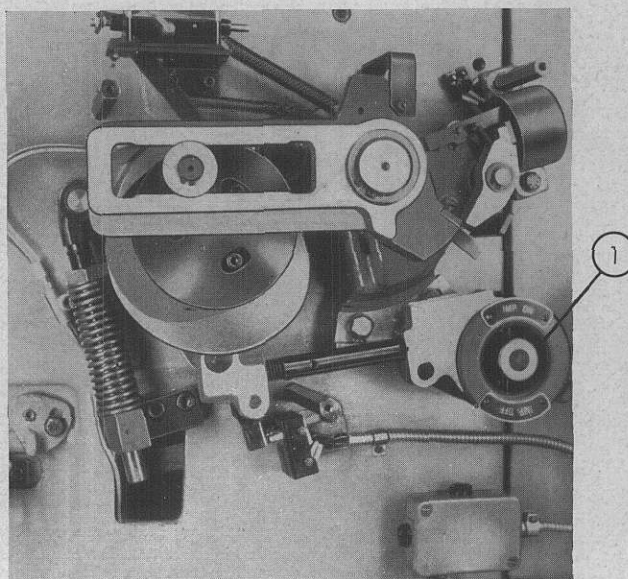

Fig. 28

The automatic control is housed in a special guard on the operator's side of the press and is shown in fig. 28. The operational wiring diagram is numbered E 16491.

To ensure satisfactory operation of the control it is necessary that the electric control contacts on the cylinder be kept constantly well adjusted and clean.

There are two adjustments to make after the contacts have been placed in the correct position to suit the size of the sheet:

- a) Operating screw 1 (fig. 29) it is possible to move the contact point of the blade back and forward in accordance with the position of the guides.
- b) Operating screw 2 (fig. 29) it is possible to adjust the pressure of the contact blade on the steel bands underneath the feedboard.

During printing the « automatic control » switch must always remain in « ON » position. It is necessary to move it to position « OFF » only:

- a) before « inching forward » ;
- b) before running the press with the feedboard up.

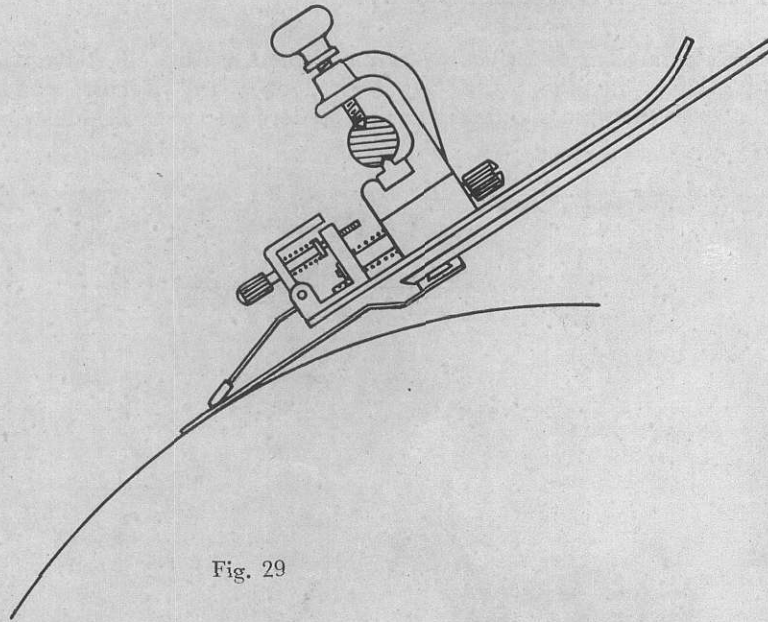

Fig. 29

The cylinder on impression and off impression control can also be operated manually by inserting a special handle in a hole in the guard. It is necessary to resort to manual operation:

- a) before starting the press with the feedboard up whenever the press has been voluntarily stopped by the operator;
- b) during regular operation of the press when a sheet correctly arrived at the front guides, is taken off the press. In this case the cylinder would remain on impression for one revolution and therefore it becomes necessary to lift it manually to avoid soiling the cylinder packing;
- c) it is also necessary to operate manually whenever one wishes to print a sheet with the feedboard up.

When the automatic controls are off the automatic cylinder on and off impression control does not operate and the cylinder will rotate always on or off impression according to its position when the control has been put off.

## INSTRUCTIONS FOR THE ELECTRICAL INSTALLATION

### Power installation.

It is necessary to install on the main supply line a main switch with fuses.

Current specifications and wire cross section specifications are given in the diagrams supplied with the press. They vary according to kind of current.

### Lighting installation.

It is necessary to install two safety fuses rated at 3 amps on the lighting supply line.

**CAUTION:** For regular operation of the press, voltage and frequency should not vary more than  $\pm 5\%$ . A greater variation may cause overheating of the motors.

### Change of Voltage and Frequency.

Instructions for changing voltage and frequency are included in the diagrams supplied with the press.

N.B. - In case of complaints always give the number of the faulty apparatus as given on the diagrams supplied with the press.

**TIMING OF FEEDER WITH PRESS DRIVE**

Exact timing of feeder and press drive is obtained when, with bed at front dead centre, that is, stroke end on inking side, the 0 (fig. 30) marked on wheel **R** corresponds with the arrow on the small plate on the left shoulder of the feeder. To correct faulty timing proceed as follows:

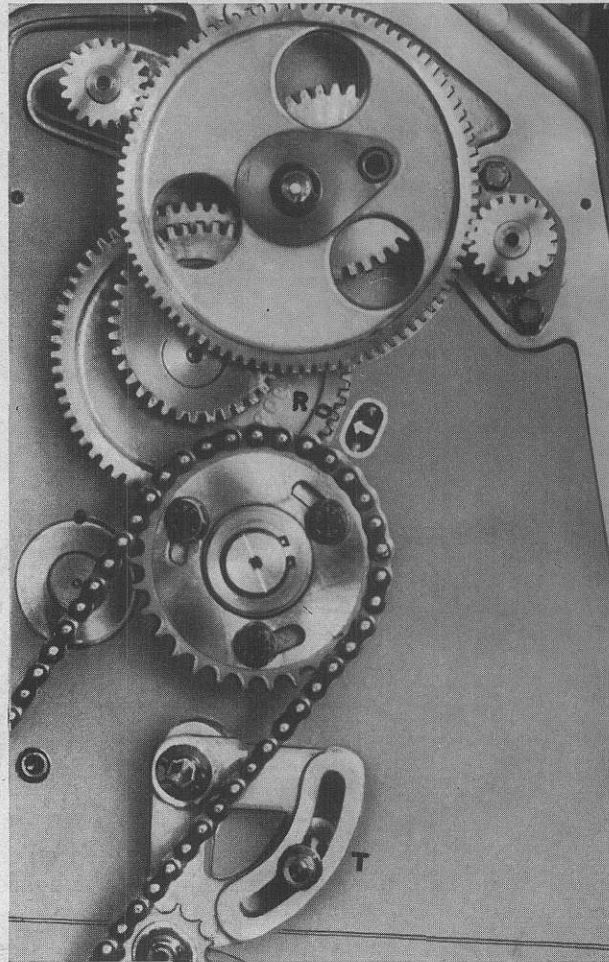
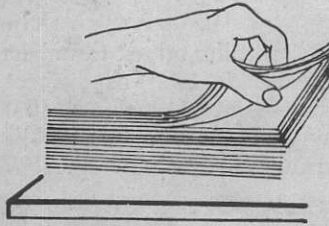

Fig. 30

- 1) Rotate flywheel by hand and bring the bed to front dead centre. To be absolutely sure to reach the exact stroke inversion point it is advisable to use a micrometer dial gauge placed on the press base and with its point in contact with the bed. Inversion point of the dial gauge pointers corresponds with bed front dead centre.
- 2) Block press in that position by operating brake lever.
- 3) Loosen chain stretcher **T** of feeder driving chain.
- 4) Open the chain at joining link after removing catch spring.
- 5) Rotate feeder gears back or forward until the 0 on wheel **R** corresponds exactly with the arrow.
- 6) Put chain back and take care that driving side (opposite to the chain stretcher) is properly under tension.
- 7) Repeat in reverse operations 3) and 4).
- 8) If the 0 on wheel **R** (fig. 30) and the arrow still do not correspond, loosen the three blocking nuts on upper chain wheel and rotate feeder gears until perfect correspondance is reached, then block upper chain wheel in that position.

FEEDER ADJUSTMENT TO PAPER SIZE



Fan through pile of paper on all sides for easy separation.

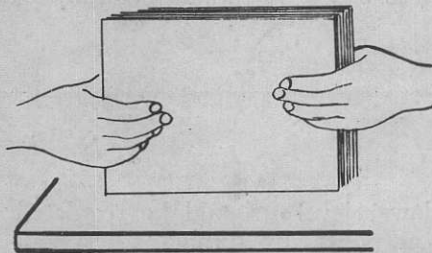

Place paper on board in small packs, after jogging. (Particularly with perfecting).

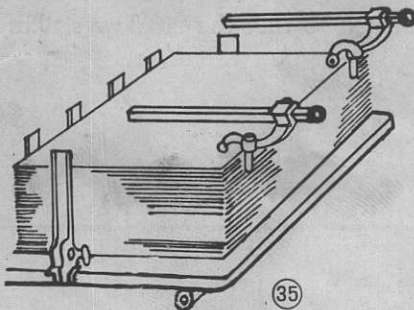

Raise rear back stops.

Place pile in centre of board with even edge well up against rack.

Bring side standards up to touch pile lightly.

Lower rear back stops and adjust depth.

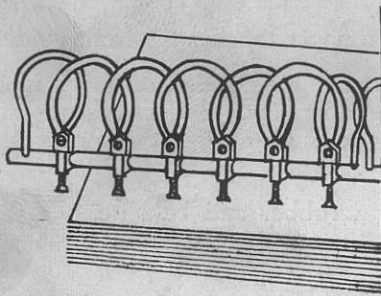

Shut off taps of suckers which are beyond paper size by turning wing to horizontal position.

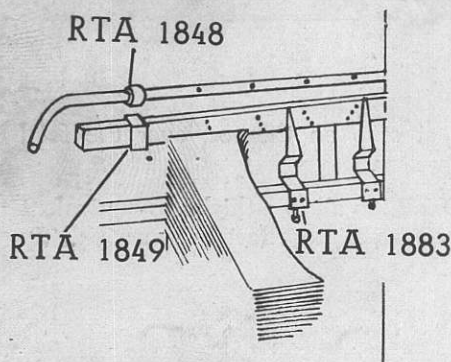

Any air holes on the two air pipes, which are beyond the paper size area, should be closed by moving the two upper rings RTA 1848 and lower slide blocks RTA 1849.

When working with light paper it may prove necessary to close some of the intermediate holes.

Paper stripper fingers should first be adjusted by turning screw RTA 1883 so that they project towards the front edge of the pile further for heavy paper, less for light paper.

## FEEDER ADJUSTMENT TO PAPER SIZE

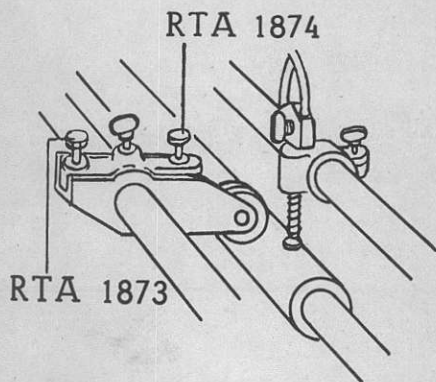

To increase or decrease tension on tension roller adjust thumbscrew RTA 1873: when tension roller, without an interposed sheet of paper, contacts directly feeder roller, an opening of only 0.004" should be left between thumbscrew point and support. Wheel pressure on paper is adjusted by turning thumbscrew RTA 1874: greater pressure for heavier paper.

**IMPORTANT!** Turn machine by hand to make certain suckers do not interfere with tension rollers. If necessary, move them.

Stop suckers at lowest point; raise board by turning hand wheel to bring pile up to suckers.

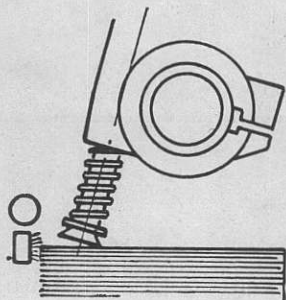

« Paper level » and « lower blower level » should be regulated afterwards according to type of paper, by turning adjustment knob according to instructions on pages 29-30. This may be done with machine in motion.

The lower blower should be adjusted so that the air flow strikes the first sheet of the pile.

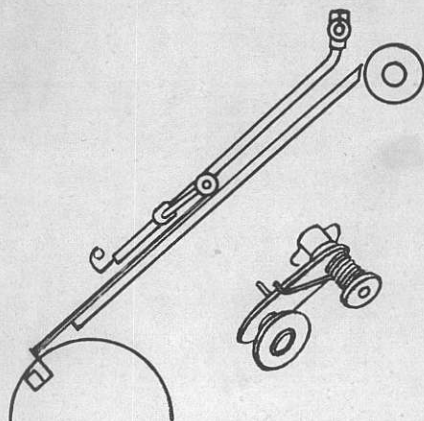

Paper must be controlled by guide rollers for the whole length of its travel down the feedboard. The back edge should be just beyond the last guide rollers when paper touches the front guides.

The number of rollers required and their position on tapes must therefore be varied according to paper size. Roller pressure can be adjusted by pressing the knurled knob against the spring and by turning.

Rollers are supplied in two types, rubber and bakelite.

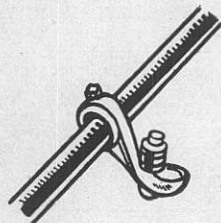

Fix a support for double sheet stop on the rod over the feed board, in the middle of paper size.

Adjust micrometric screw PVD 1628 to allow a thickness equivalent to two sheets of paper to pass with slight effort between ball tip and feed board.

## FEEDER ADJUSTMENT TO TYPE OF PAPER

**FEEDER UPPER BLOWER (1).**

**FEEDER LOWER BLOWER (2).**

**DELIVERY BLOWER (3).**

By moving indicator from (—) towards (+) (thus increasing air blow) adjustment is made starting from light paper (flimsy) to heavy paper (board).

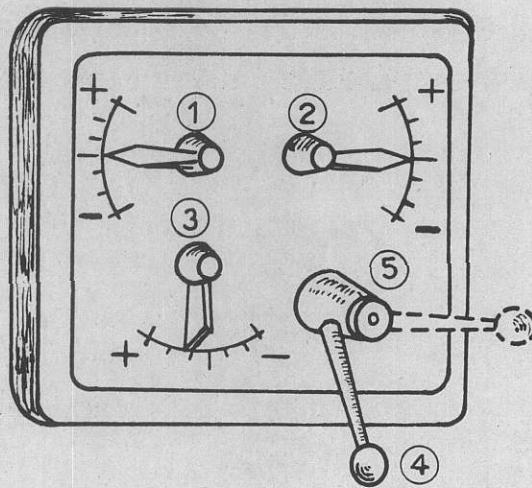

### SUCTION

By **unscrewing** knurled nut (5) suction is reduced (light paper). For very light flimsy paper fit sucker perforated caps (supplied with accessories).

By **tightening** knurled nut (5) suction is increased (board). For very heavy board fit rubber suckers (supplied with accessories).

### PAPER SUCKER CONTROL LEVER (4).

- Horizontal: suckers are inoperative.
- Vertical: suckers are operative.

### SHEET TURNING CYLINDER BLOWER

Helps cylinder to turn the sheet and lay it on tapes. It is particularly useful with large paper sizes.

Rotate indicator (6) from (—) toward (+), thus increasing air blow, as size increases and stiffness of paper decreases.

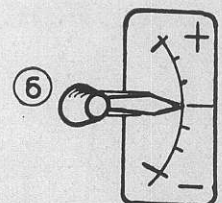

**SUCKER ANGLE**

Adjustment of sleeve (7) varies the sucker angle when picking up paper.

**For light paper**, adjust sleeve (7) to shorten tie-rod. By doing this the suckers tilt *rotating clockwise*.

**For heavy paper**, adjust sleeve (7) to lengthen tie-rod. By doing this the suckers rotate *anti-clockwise* returning to a vertical position and if necessary tilting in the opposite direction.

**SUCKER FANNING ACTION**

By adjusting sleeve (8) the suckers swing wider after picking up the paper.

**For light paper** adjust sleeve (8) to shorten tie-rod, thus increasing sucker swing.

**For heavy paper**, adjust sleeve (8) to lengthen tie-rod, thus reducing sucker swing down to zero if required.

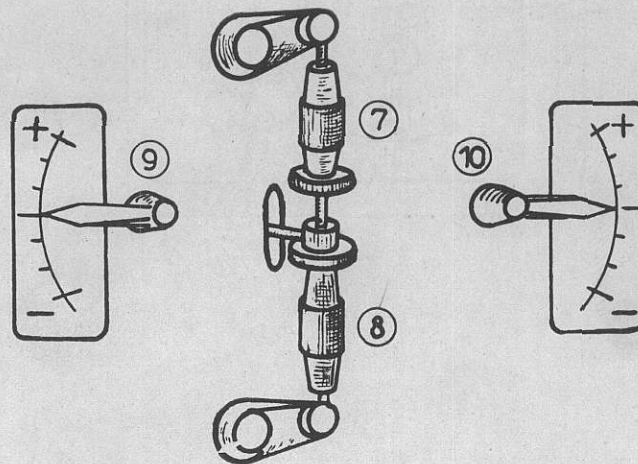



**BLOWER LEVEL**

Rotate indicator (9) from (—) towards (+) (thus raising level) to pass from light to heavy paper.

**PAPER LEVEL**

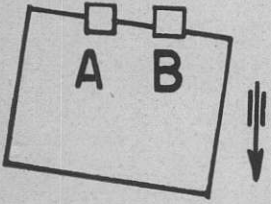
Rotate indicator (10) from (—) towards (+) (thus raising level) to pass from light to heavy paper.

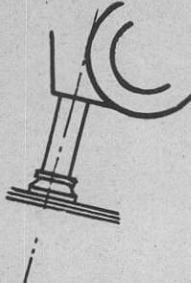
F E E D E R

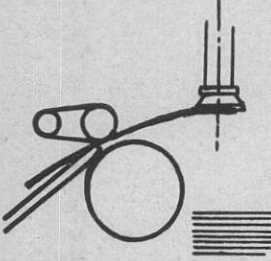
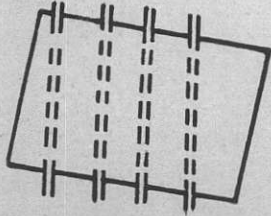
T R O U B L E	C A U S E S	H O W T O C O R R E C T
 <p>Sheet dropping crookedly</p>	<p>Uneven tension roller pressure at A and B.</p> <p>Tape stretcher pulleys not rotating properly.</p>	<p>Increase pressure on roller A decrease pressure on roller B.</p> <p>Clean with petrol and lubricate with oil.</p>
 <p>Sheet is torn or creased.</p>	<p>Paper level too high.</p> <p>Air draft near corner.</p>	<p>Adjust paper level.</p> <p>Stop blow-hole by sliding block RTA 1848 and RTA 1849.</p>
 <p>Two or more sheets picked up simultaneously.</p>	<p>Paper level too high.</p> <p>Sucker angle insufficient.</p> <p>Excess suction.</p> <p>Insufficient air draft.</p> <p>Lower blower level not correctly adjusted.</p>	<p>Adjust paper level.</p> <p>Shorten tie-rod.</p> <p>Adjust air suction.</p> <p>Adjust air blow.</p> <p>Adjust blower pipe level.</p>
 <p>Sheet not picked up by suckers occasionally.</p>	<p>Paper level too low.</p> <p>Insufficient suction.</p> <p>Lower blower pipe level not correct.</p> <p>Sheet separating metal strips RTE 1883 too close to pile.</p>	<p>Adjust paper level.</p> <p>Adjust air suction.</p> <p>Adjust lower blower pipe level.</p> <p>Detach strips from pile.</p>
 <p>When returning suckers catch and stop previous sheet.</p>	<p>Insufficient pressure on tension rollers.</p>	<p>Increase tension roller pressure.</p>
 <p>Machine fails to stop when paper drops unevenly.</p>	<p>« Paper Feeder » switch left in « off » position.</p> <p>Electric contacts dirty.</p> <p>Trouble in electric plant.</p>	<p>Turn lever to « in » position.</p> <p>Clean.</p> <p>Call electrician to check.</p>

- ① Brake control lever.
- ② Control box.
- ③ Pump switch.
- ④ Speed control lever.
- ⑤ Flywheel.
- ⑥ Handwheel for manual operation of stock pile board.
- ⑦ Automatic stock pile elevator cut-out lever.
- ⑧ Sucker angle adjustment sleeve.
- ⑨ Sucker fanning action adjustment sleeve.
- ⑩ Paper level adjustment lever.
- ⑪ Blower pipe level adjustment lever.
- ⑫ Ductor roller control lever locknut for roller cleaning.
- ⑬ Feedboard lifting handle.
- ⑭ Suction air flow cut-out lever and suction air control valve.
- ⑮ Lower blower pipe air control lever.
- ⑯ Upper blower pipe air control lever.
- ⑰ Delivery air control lever.
- ⑱ Sheet turning cylinder air control lever.
- ⑲ Handwheel for manual operation of delivery board.
- ⑳ Delivery table automatic lowering device cut-out lever.
- ㉑ Paper delivery jogger travel adjustment screw.
- ㉒ Cylinder lifting lever.
- ㉓ Handwheel for fountain roller manual rotation.
- ㉔ Ink fountain roller intermittent rotation adjustment lever.
- ㉕ Ink fountain locking wing bolts.
- ㉖ Inking adjustment
- ㉗ Distributing and ductor roller releasing knobs.
- ㉘ Distributing rollers journal box locking wing bolts.
- ㉙ Form inking rollers journal box wing locking bolts.
- ㉚ Form inking rollers vertical adjustment nut.
- ㉛ Form inking rollers journal box locking bolts.
- ㉜ Brush adjustment lever.

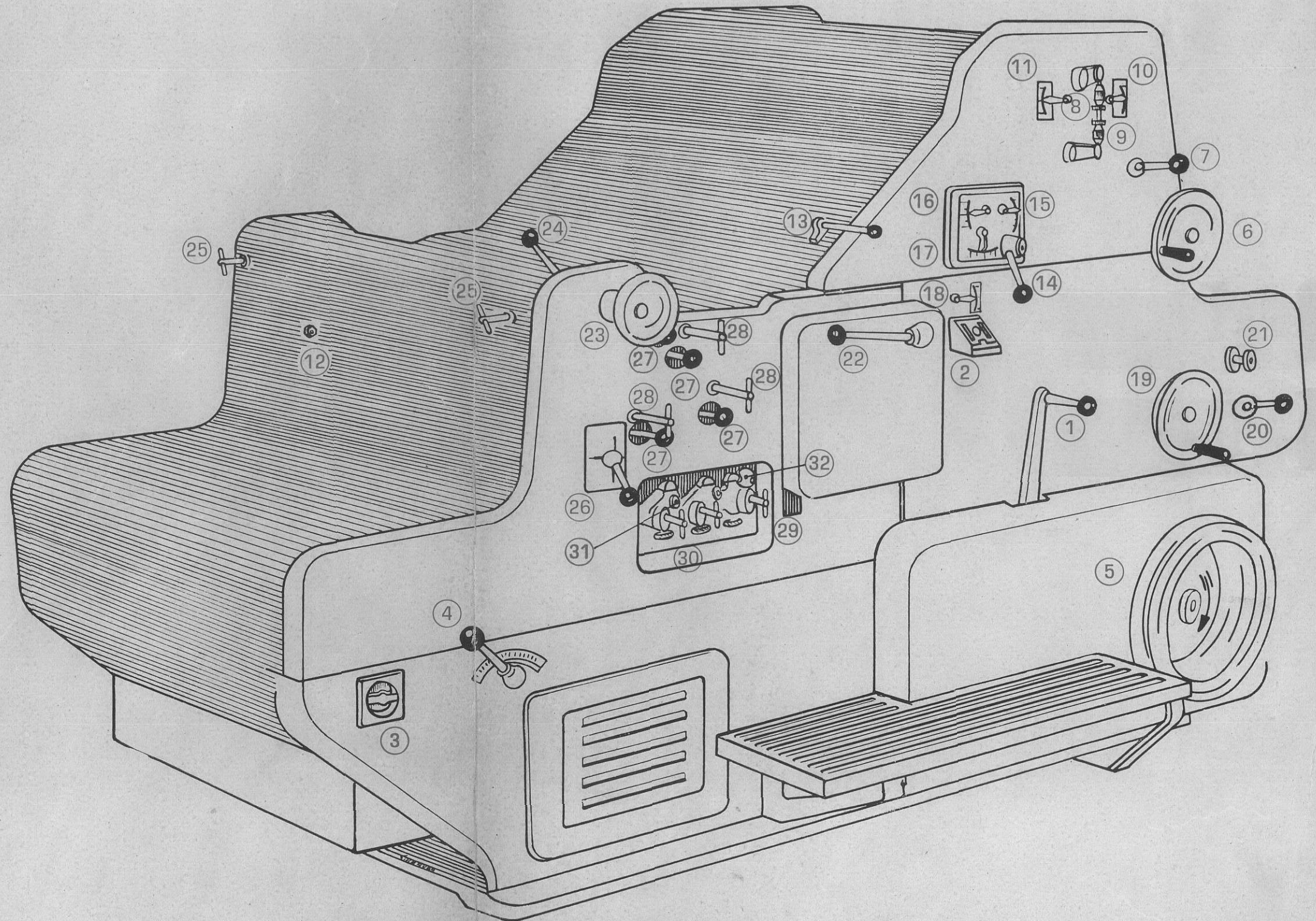

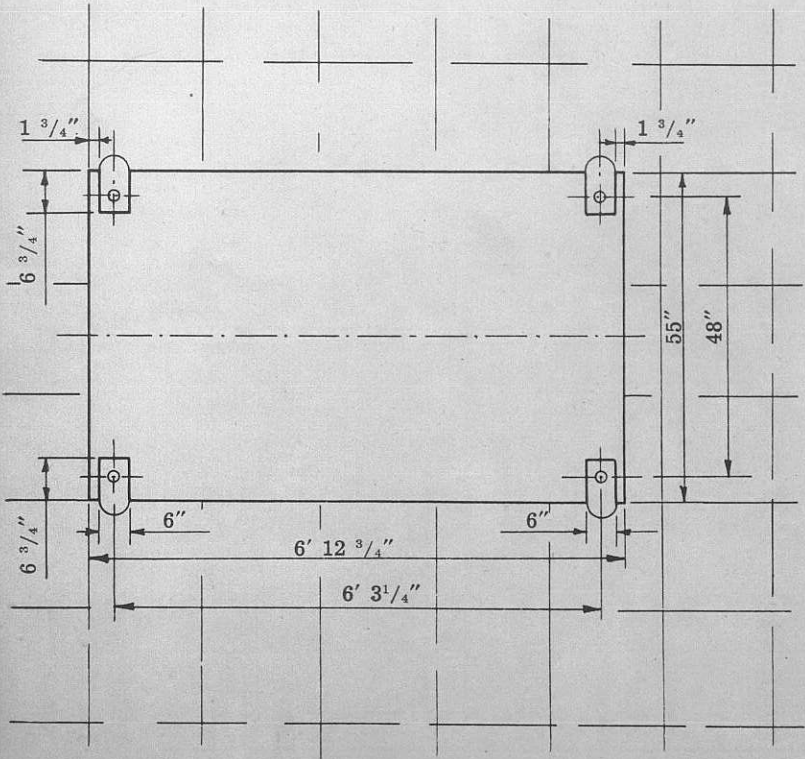
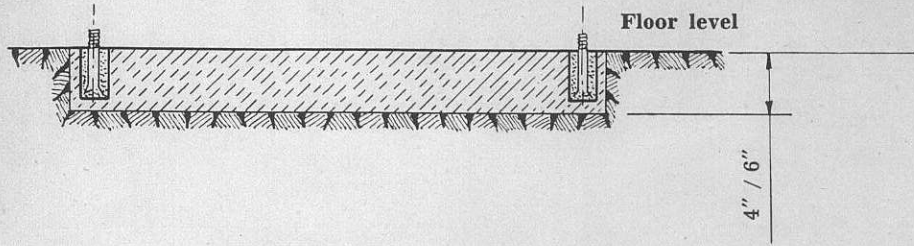

N. 4 foundation bolts

$\varnothing \frac{9}{16} \div \frac{5}{8} \times 8"$

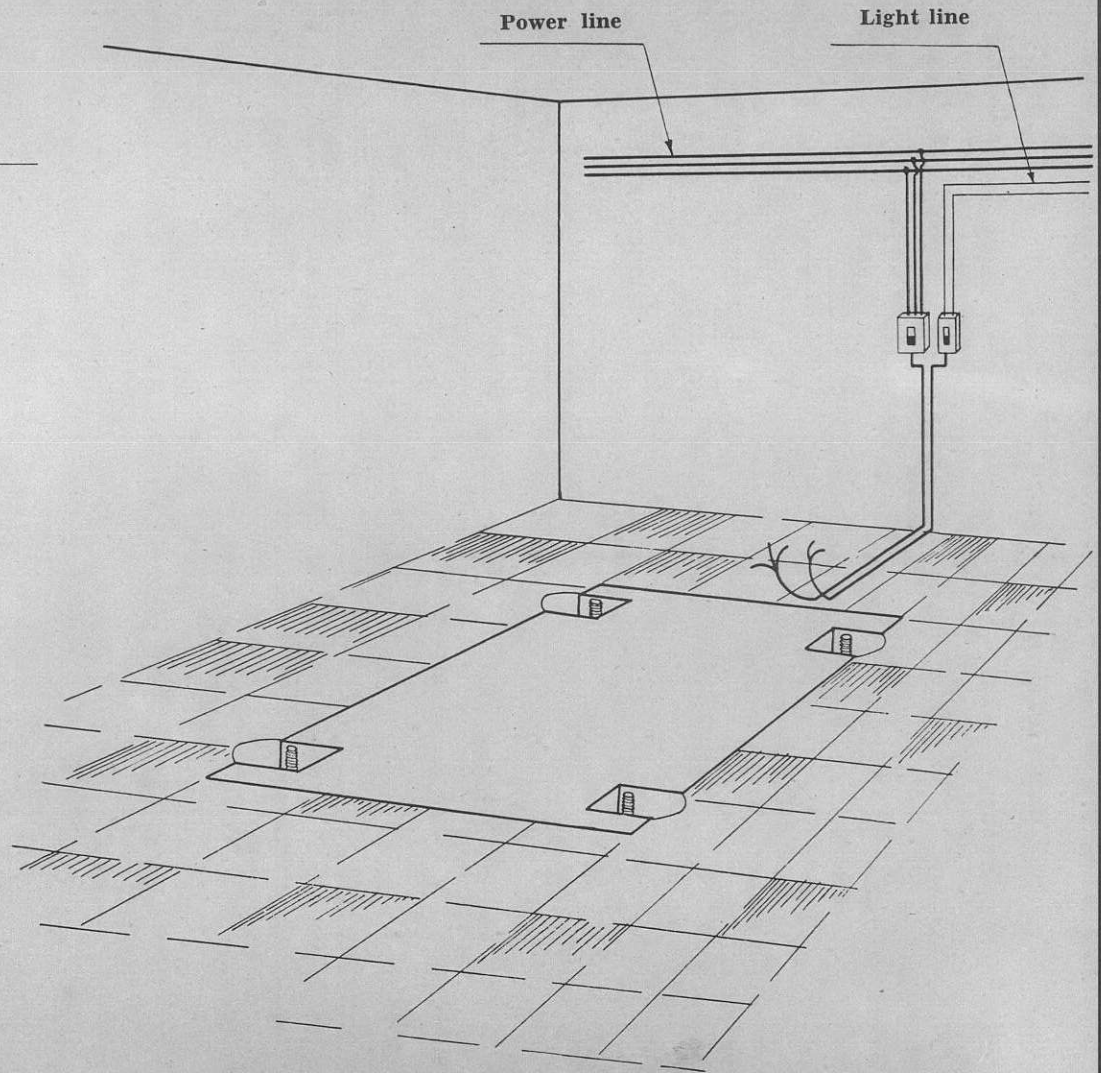

OVERALL DIMENSIONS

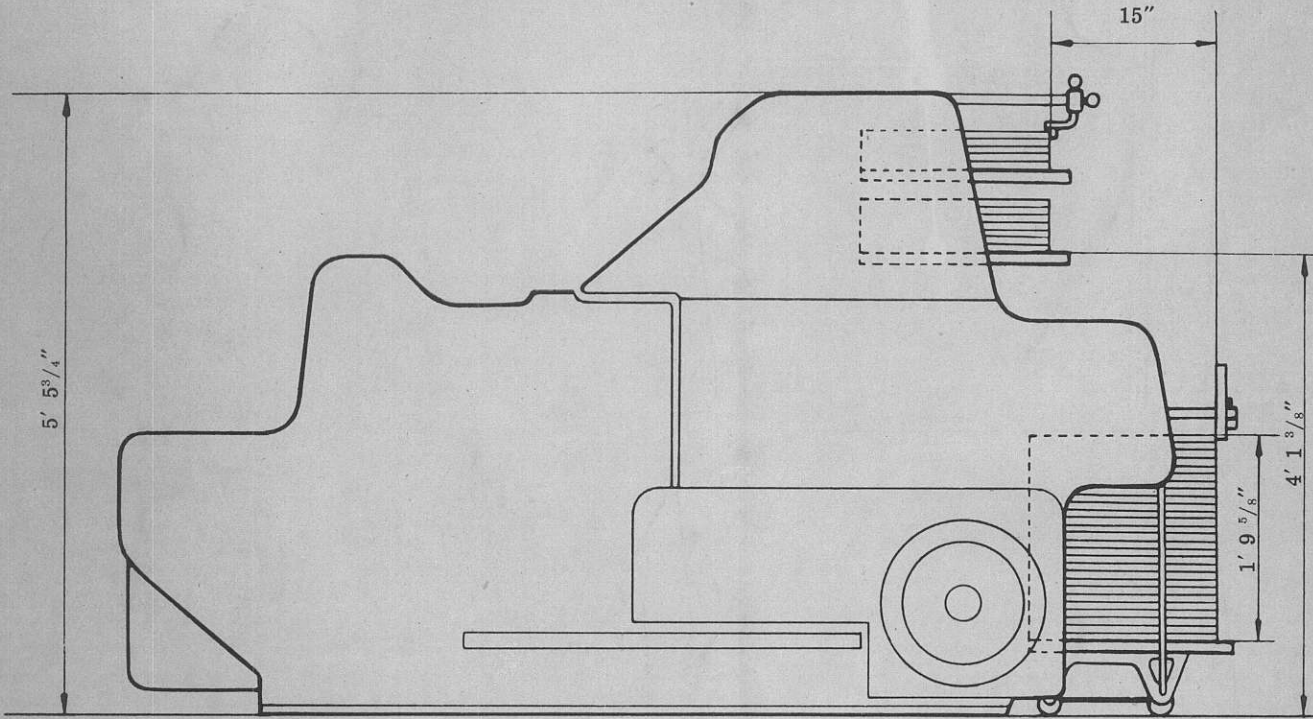

AND FLOOR SPACE DIAGRAMS

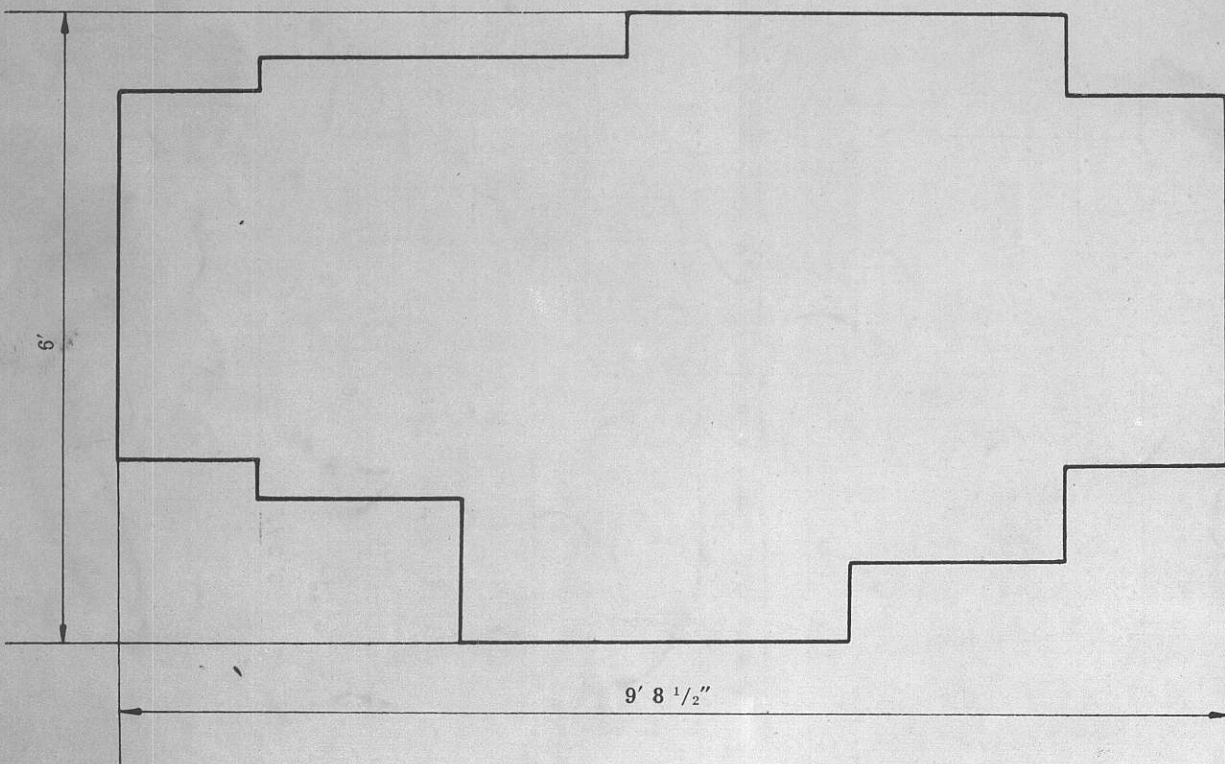

Machine Model	Part Number	Item Description	Unit Price
Heidelberg T-10x15	T0104	Chase Lug	\$ 7.40
	T0207	Tympan Bar	\$ 2.30
	T0208	Tympan Bar	\$ 2.00
	T0209	Clip W/0274	\$ 1.30
	T0210F	Clip	\$ .80
	T0217F	Adjusting Screw	\$ 1.70
	T0220	Lay Gauge	\$ 5.40
	T0229	Cheese Head Screw	\$ 1.40
	T0241	Nickel Guide	\$10.80
	T0242	Nickel Guide	\$18.30
	*T0244	Lay Pin	\$ .20
	*T0252	Paper Guide	\$23.20
	T0255	Spring	\$ .20
	T0262	Spring	\$ .20
	*T0264	Brass Guide	\$13.20
	*T0265	Brass Guide	\$15.50
	*T0269	Hex Nut	\$ .20
	*T0278	Ext. Side Lay Gauge	\$ 9.70
	*T02146	Lay Pin	\$ .20
	*T02147	Lay Pin	\$ .20
	*T02148	Lay Pin	\$ .50
	*T02149	Lay Pin	\$ .50
	*T02150	Lay Pin	\$ .50
	T0443	Clutch Tongue	\$ 6.70
	T0622F	Safety Catch Cpl	\$ 7.00
	T0673	Bracket	\$ 7.40
	T0674	Support Bar	\$19.70
	T0675	Hex Screw	\$ 4.00
	T0685	Compression Spring	\$ 1.00
	T0696	Cheese Head Screw	\$ 1.40
	T0699	Spring Catch Cpl.	\$ 7.50
	T06105F	Rubber Cleaner	\$18.40
	*T0819	Rubber Clamp	\$15.10
	*T0824	Screw	\$ 4.70
	T0901	Roller Cone	\$10.50
	T0911	Runner	\$ 7.20
	T1056	Clamping Nut	\$ 5.80
	T1072	Round Ball Standard	\$17.80
	T1082	Rubber Hose	\$ 1.70
	T1083	Rubber Hose	\$ 1.70
	T1103	Pawl	\$13.90
	T1121	Gear Wheel	\$ 7.40
	T1127	Checking Pawl	\$13.90
	*T1203	Trip Spring	\$ 1.40
	*T1231	Holder	\$ 6.70
	*T1232	Trip Spring	\$ .20
	*T1233	Trip Spring	\$ .20
	*T1234	Trip Spring	\$ .20
	*T1235	Trip Spring	\$ .20
	*T1240	Rubber Hose	\$10.50
*T1244	Flat Rod	\$ 2.10	
*T1249	Sheet Separation Spring	\$ 2.10	
*T1307	Screwed Rivets	\$ 1.40	
*T1310	Shouldered Pin	\$ 4.70	

\* Fit Various Model Machines--See GT Listing

ALL PRICES LISTED ABOVE ARE SUBJECT TO CHANGE WITHOUT NOTICE.

Machine Model	Part Number	Item Description	Unit Price	
Heidelberg T-10x15	*T1311	Roller	\$ 6.70	
	*T1315	Ball End Pin	\$ 4.70	
	T1326	Torsion Spring	\$ 1.40	
	T1327	Torsion Spring	\$ 1.05	
	*T1412/8	Locking Pawl Cpl	\$16.10	
	*T1610	Spindle Cpl	\$22.00	
	*T1622	Plunger Cpl	\$13.20	
	*T1625	Rubber Sucker	\$ .20	
	*T1634	Rubber Hose	\$22.00	
	*T1667	Air Filter	\$ 2.10	
	T1678	Red Slide	\$ 4.00	
	T1688	Yellow Slide	\$ 4.00	
	T1689	Pink Slide	\$ 8.40	
	T1710	Tension Spring	\$ 1.40	
	*T1808	Pin	\$13.90	
	*T1812	Spring	\$ .70	
	*T1816	Air Valve Spring	\$ .50	
	*T1817	Plate	\$ .70	
	*T1818	Rubber Hose	\$17.80	
	T2002	Frisket Bar	\$15.10	
	T2006	Frisket	\$13.90	
	T2009	Cross Frisket	\$ 4.00	
	T2010/2BK1	Screw W/U-1	\$ 4.70	
	T2012/2K1	Plate Cpl	\$ 9.50	
	T2012/2	Plate Only	\$ 4.70	
	T2028	Double Cross Frisket	\$ 4.70	
	T2148	Wire Only	\$ 5.40	
	T2171	Rivet	\$ .10	
	T2219F	Holder Cpl	\$13.20	
	T2327	Tube Clamp	\$ 1.40	
	T2350	Nozzle	\$ 1.60	
	*T2416	Box Spanner	\$ 2.30	
	*T2418	Box Spanner	\$ 2.30	
	*T2425F	Imm Drill W/Holder	\$ 4.00	
	*T2462	Oil Gun	\$18.30	
	*T6014F	Compression Spring	\$10.50	
	Heidelberg KS-15x20 $\frac{1}{2}$	KS1045/G	Guide Block Only	\$10.80
		KS1047/G	Guide Block Only	\$ 9.80
		KS1048/GK1	Journal Box Cpl	\$24.30
		KS1060/D	Journal Box Cpl	\$16.20
		KS10180F	Washup Blade	\$ 4.10
		KS1150	Rod F/Blanket	\$ 2.30
		KS1296	Guide Basin	\$ 7.50
		KS1297	Dirt Basin	\$14.20
		KS1371	Curved Spring	\$ .70
		KS1375/A	Plunger	\$ 7.60
		KS1539	Delivery Cable	\$ 7.00
		KS1587/K1	Trip Plate O.S.	\$14.20
		KS1587/K2	Trip Plate N.S.	\$12.80
		KS15101	Forked Lever	\$ 7.80
		KS15103	Square Bolt	\$ 1.90
		KS15110	Flat Alum Bag	\$ 4.20
		KS15112	Plastic Finger	\$ 1.40
		KS1671	Rubber Sucker	\$ .50

\* Fit Various Model Machines--See GT Listing

ALL PRICES LISTED ABOVE ARE SUBJECT TO CHANGE WITHOUT NOTICE.

Machine Model	Part Number	Item Description	Unit Price	
Heidelberg KS-15x20 $\frac{1}{2}$	KS1777	Guide Piece	\$14.20	
	KS1785	Trip Spring W/Sponge	\$ 2.30	
	KS1808	Rubber Hose	\$ 5.40	
	KS1815	Plastic Hex Screw	\$ 1.40	
	KS2461	Grease Gun	\$24.30	
		Nylon Ring For Pulley	\$27.40	
	KS100.051	Hex Screw	\$ 2.60	
	KS100.052	Grease Fitting	\$ 1.30	
	Heidelberg S-21x28	S0705	Pivot Bolt	\$12.90
		S0708/2C	Chase Lock D.S.	\$19.20
S0709/2C		Chase Lock O.S.	\$17.40	
S0710/E		Lock Screw	\$ 9.80	
S0711/1E		Locking Nut	\$ 7.00	
S0719/1A		Chase Screw	\$ 2.00	
S1539		Delivery Cable		
Note: Parts Listed Above - Fit All "S" Line Letter Press				
Heidelberg KOR-15 3/4x22 $\frac{1}{2}$	S1018/7	Spigot	\$18.20	
	S1026/4	Pin	\$ 4.30	
	S1033/8A	Knob	\$ 6.20	
	S1091/7	Comp. Spring	\$ 1.90	
	S10180/2	Washup Blade	\$13.60	
	S1374/4BK1	Lever W/1377	\$ 8.70	
	S1376/2	Toggle	\$ 3.50	
	S1377/2	Spring Plate	\$ .40	
	S1409/B	Torsion Spring	\$ 1.30	
	S1607F/2	Sucker	\$15.40	
	S1630/3A	Red Rubber Sucker	\$ .50	
	S1820/	Valve	\$ 5.80	
	S2420	Pin Wrench	\$ 2.30	
	S2420	Pin Wrench	\$ 2.30	
	S2462	Oil Gun	\$21.90	
	KS1045/G	Guide Block Only	\$10.80	
	KS1047/G	Guide Block Only	\$ 9.80	
	KS1048/GK1	Journal Box Cpl	\$24.30	
	KS1539	Delivery Cable	\$ 7.00	
	KS1587/K2	Trip Plate	\$12.80	
	KS15112	Plastic Finger	\$ 1.40	
	KS1671	Rubber Sucker	\$ .50	
	KS1777	Guide Piece	\$14.20	
	KS1785	Trip Spring W/Sponge	\$ 2.30	
	KS1808	Rubber Hose	\$ 5.40	
	KS1815	Plastic Hex Screw	\$ 1.40	
	KS2461	Grease Gun	\$24.30	
	KOR0944	Mollettin Cover	\$ 6.50	
	KOR10811	Insert Cpl	\$18.80	
	KOR1082	Insert Cpl	\$19.70	
	KOR10102	End Support	\$ 2.20	
	KOR10104	Nylon Bushing	\$ .80	
KOR1801	Plastic Hose	\$ 6.60		
KOR2404	Feeler Gauge	\$ 1.10		
KOR2420	Pin Wrench	\$ 6.50		
KOR2440	Plastic Bottle	\$ 7.60		
	Nylon Ring For Pulley	\$27.40		

ALL PRICES LISTED ABOVE ARE SUBJECT TO CHANGE WITHOUT NOTICE.

Machine Model	Part Number	Item Description	Unit Price	
Heidelberg KOR-15 3/4x22 1/2	KS100.051	Hex Screw	\$ 2.60	
	KS100.052	Grease Fitting	\$ 1.30	
	KS18503	Needle Bearing	\$ 4.20	
	KS18504	Needle Bearing	\$ 4.90	
Heidelberg KORA-18x22 1/2	See KOR Listing			
Heidelberg KORD-18x24 1/2 (62) Model	See KOR Listing			
Heidelberg KORD-18x25 1/4 (64) Model	See KOR Listing			
Heidelberg KORS-20 1/2 x 28 3/8	See KOR Listing			
Heidelberg GTO-13x18 Offset	GT00711	Knurled Nut	\$ 3.00	
	GT00944	Mollettin Cover	\$ 7.70	
	GT01180	Metal Packing Jacket	\$26.10	
	GT01244	Compression Spring	\$ 1.70	
	GT01258/AK1	Lever	\$ 9.50	
	Heidelberg GT-13x18	GT06101	Rubber Strip	\$10.70
		GT1678	Red Slide	\$ 4.70
GT1688		Yellow Slide	\$ 4.70	
GT1689		Pink Slide	\$ 9.40	
GT1724		Shear Bolt	\$13.20	
Note: See Items With * Listed in T-10x15				
Heidelberg SOR-24x32 1/4	SOR0944	Mollettin Cover	\$11.50	
	*SOR16123	Shear Pin	\$ 4.00	
	*SOR20122	Roller Brush Paper	\$12.80	
	*SOR28401	Rubber Sucker Small	\$ .70	
	*SOR28402	Rubber Sucker Large	\$ .10	
	*SOR28403	Small Plastic Sucker	\$ .10	
	*SOR28404	Large Plastic Sucker	\$ .10	
	*SOR28405	Rubber Sucker Pad	\$ 2.50	
	*SOR28406	Red Rubber Sucker 1 1/4"	\$ .10	
	*SOR28409	White Plastic Sucker Head	\$ 2.30	
	*SOR3069	Liner Cover	\$13.90	
Heidelberg SORD-25 1/4 x 36	SORD0944	Mollettin Cover	\$11.60	
	SORD3069	Liner Cover	\$15.10	
	Note: See Items With * Listed in SOR			
Heidelberg SORK	SORK0944	Mollettin Cover	\$ 9.80	
	SORK3069	Liner Cover	\$12.20	
Note: See Items With * Listed in SOR				
Heidelberg SORS	SORS0944	Mollettin Cover	\$15.50	
Note: See Items With * Listed in SOR				

ALL PRICES LISTED ABOVE ARE SUBJECT TO CHANGE WITHOUT NOTICE.

Machine Model	Part Number	Item Description	Unit Price
Polar Model #115EL	010784-M	Plastic Clamp Pressure Pedal	\$13.60
	205206-M	V Belt 12.5x2000	\$17.90
	217884-M	Hydr. Hose	\$16.10
	205869-M	Hose Clip	\$ 1.50
	205698-M	Spring for Hyd. Hose	\$ 2.80
	205912-M	Link	\$ 9.20
	210284-M	Toggle Switch	\$ 7.30
	211013-M	ST103 Starter	\$ 2.80
	210983-M	Fluorescent Lamp 30W	\$ 7.40
	211004-M	Socket	\$ 2.40
	211012-M	30W Ballast	\$19.40
	200292-M	Knife Bolt	\$ 1.00
	010034-M	Eccentric Handle	\$14.70
	207466-M	Shearbolt	\$ 5.30
	205517-M	Shearbolt-Nut	\$ .60
	206036-M	False Clamp Lock Pin Assembly CPL	\$ 6.10
	206035-M	False Plate Pin	\$ 1.50
	206701-M	Pin	\$ .80
	206689-M	Plastic Support	\$ 4.20
	210962-M	6V5W Bulb	\$ 7.30
	210985-M	6V1.2W Bulb	\$ 3.10
	210890-M	Photo Element	\$20.40
	210970-M	12V35W Bulb	\$ 4.20
	211005-M	Socket	\$ 4.30
	210986-M	12V1.2W White Bulb	\$ 3.10
	210992-M	24V1.2W Bulb	\$ 3.80
	010174-M	Pinion Bear	\$14.10
	206286-M	Clutch Pinion Bear	\$11.60
	206293-M	Handle	\$19.60
	010060-M	Brake Ring	\$42.00
	205180-M	VBelt 10x1060	\$ 3.50
	207611-M	Glass Screen	\$12.50
	210972-M	12V45W Bulb	\$ 6.90
	211005-M	Socket	\$ 4.30
	210413-M	Micro Switch	\$ 6.10
	011686-M	Mag. Head	\$54.00
	013726-M	Cam	\$12.10
	211098-M	AT11D-2-I Limit Switch	\$30.70
	207555-M	Cutting Stick	\$ 2.80
	206624-M	Cutting Stick Stop Right	\$ 2.20
	206625-M	Cutting Stick Stop Left	\$ 2.20
	206273-M	Toothed Wheel	\$18.70
	210262-M	Reverse Switch	\$ 6.80
	207517-M	Short Side Guide Rt.	\$39.40
	210611-M	Brush Holder (4x4)	\$ 1.40
	210612-M	Carmon Brush (4x4)	\$ 1.40
	207015-M	Oil Reservoir	\$ 2.50
	010119-M	T Wrench 6 M.M.	\$ 8.20
	010120-M	T Wrench 10 M.M.	\$11.20
	010510-M	Clutch Handles	\$12.90
	010113-M	Knife Holder	\$13.70

ALL PRICES LISTED ABOVE ARE SUBJECT TO CHANGE WITHOUT NOTICE.

Machine Model	Part Number	Item Description	Unit Price	
Polar Model #115EL	205335-M	Grease Gun	\$16.00	
	207315-M	Knife Handle	\$16.10	
	010662-M	Knife Stand Right	\$33.90	
	010661-M	Knife Stand Left	\$33.90	
	010659-M	Knife Gauge	\$ 8.90	
	013752-P	Hyrd. Oil	\$ 4.60	
	013753-P	Gear Oil	\$ 2.60	
	013754-P	Spindle Oil	\$ 2.00	
	459988-P	Spare Parts Book	\$ 9.40	
	459982-P	Inst. Manual	\$ 3.50	
	Polar Model #115CE	211098-M	Limit Switch AT11D-2-1	\$30.70
		010784-M (010028)	Plastic Clamp Pressure Pedal	\$13.60
		207997-M	V Belt 12x1157	\$ 6.80
		205217-M	V Belt 16x1800 (1778)	\$22.00
217884-M		Hydr. Hose	\$16.10	
205869-M		Hose Clip	\$ 1.50	
205698-M		Spring for Hydr. Hose	\$ 2.80	
205912-M		Link	\$ 9.20	
210284-M		Toggle Switch	\$ 7.30	
211013-M		ST103 Starter	\$ 2.80	
210983-M		Fluorescent Lamp 30W	\$ 7.40	
211004-M		Socket	\$ 2.40	
211012-M		30W Ballast	\$19.40	
200292-M		Knife Bolt	\$ 1.00	
010034-M		Eccentric Handle	\$14.70	
207466-M		Shear Bolt	\$ 5.30	
205517-M		Shear Bolt Nut	\$ .60	
206036-M		False Clamp Lock Pin Assembly CPL	\$ 6.10	
206035-M		False Plate Pin	\$ 1.50	
206701-M		Pin	\$ .80	
206689-M		Plastic Support	\$ 4.20	
210962-M		6V5W Bulb	\$ 7.30	
210991-M		24V1.5 Raffi Bulb	\$ 1.50	
210971-M		12V35W Fischer 2 Pole Bulb	\$ 3.10	
211006-M		Socket	\$ 4.30	
207517-M		Shortside Guide Right	\$39.40	
211459-M (210994)		24V1.2W Bulb	\$ 3.10	
210993-M		24V1.2W Bulb	\$ 1.50	
010053-M		Cut Button Only	\$20.90	
210414-M		GVCF Micro Switch	\$ 7.00	
207555-M		Cutting Sticks	\$ 2.80	
206624-M		Stop Right Cutting Stick	\$ 2.20	
206625-M		Stop Left Cutting Stick	\$ 2.20	
206273-M		Toothed Wheel	\$18.70	
010591-M	Pinion	\$ 8.90		
206293-M	Handle	\$19.60		
210262-M	Reverse Switch	\$ 6.80		
210611-M	Brush Holder (4x4)	\$ 1.40		
210612-M	Carbon Brush (4x4)	\$ 1.40		

ALL PRICES LISTED ABOVE ARE SUBJECT TO CHANGE WITHOUT NOTICE.

Machine Model	Part Number	Item Description	Unit Price	
Polar Model #115CE	206286-M	Clutch Pinion Bear	\$11.60	
	010060-M	Brake Ring	\$42.00	
	010063-M	Brake Ring	\$42.00	
	205180-M	V Belt 10x1060	\$ 3.50	
	207015-M	Oil Reservoir	\$ 2.50	
	207611-M	Glass Screen	\$12.50	
	210971-M	12V35W Bulb	\$ 3.10	
	211006-M	Socket	\$ 4.30	
	216745-M	Shift Fork	\$25.40	
	011686-M	Mag Head	\$54.00	
	010801-M	Air Jet	\$ 1.40	
	013726-M (010108)	Cam	\$12.20	
	010120-M	"T" Wrench 10 M.M.	\$11.20	
	010119-M	"T" Wrench 6 M.M.	\$ 8.20	
	010510-M	Clutch Handles	\$12.90	
	010113-M	Knife Holder	\$13.70	
	205335-M	Grease Gun	\$16.00	
	207315-M	Knife Handle	\$16.10	
	010661-M	Knife Stand Left	\$33.90	
	010662-M	Knife Stand Right	\$33.90	
	010659-M	Knife Gauge	\$ 8.90	
	013752-P	Hydr Oil	\$ 4.60	
	013753-P	Gear Oil	\$ 2.60	
	013754-P	Spindle Oil	\$ 2.00	
	010800-M	Air Jet	\$ 1.40	
	Polar Model #71STD	207901-M	Cutting Stick	\$ 2.20
		010784-M	Plastic Clamp Pressure Pedal	\$13.60
		010034-M	Eccentric Handle	\$14.70
		010288-M	Knife Bolt 10x20	\$ 1.50
		216198-M	False Clamp Lock Pin Assembly CPL	\$ 3.50
		211819-M	12V20W (7983) Bulb	\$ 5.00
		210970-M	12V35W Bulb	\$ 4.20
		210969-M	12V25W Bulb	\$ 6.60
		211847-M	Socket	\$ 4.60
		211005-M	Socket	\$ 4.30
		211010-M	Socket	\$ 3.00
		010053-M	Cut Button Only	\$20.90
		210414-M	Micro Switch GVCF	\$ 7.00
		210284-M	Toggle Switch	\$ 7.30
		206224-M	Cutting Stick Stop Right	\$ 2.20
		206225-M	Cutting Stick Stop Left	\$ 2.20
		206293-M	Handle	\$19.60
		210262-M	Reverse Switch	\$ 6.80
206273-M		Toothed Wheel	\$18.70	
206286-M		Claw Clutch	\$11.60	
210611-M		Brush Holder (4x4)	\$ 1.40	
210612-M		Carbon Brush (4x4)	\$ 1.40	
207715-M		12x1232 V Belt	\$14.30	
207933-M		10x520 V Belt	\$ 5.60	
300006-P		71ST Parts Book	\$ 4.80	
300008-P		71ST Inst. Book	\$ 2.10	

ALL PRICES LISTED ABOVE ARE SUBJECT TO CHANGE WITHOUT NOTICE.

Machine Model	Part Number	Item Description	Unit Price
Polar Model #71STD	210610-M	Carbon Brush 10x15x6	\$ 1.40
	211098-M	Limit Switch AT 11D-2-I	\$30.70
	209563-M	Piston Oil Pump	\$ 9.70
	013752-P	Hydr Oil (Gal)	\$ 4.60
	013753-P	Gear Oil (Qt)	\$ 2.60
	013754-P	Spindle Oil	\$ 2.00
	206579-M	Knife Handles	\$ 3.30
	215227-M	Clutch Handle	\$19.60
	010859-M	T Wrench	\$ 9.70
	Polar Model #72CE	217466-M	Cutting Stick
010784-M		Plastic Clamp Pressure Pedal	\$13.60
010034-M		Eccentric Handle	\$14.70
013551-M		Knife Bolts	\$ 1.70
216198-M		False Clamp Lock Pin Assembly CPL	\$ 3.50
211819-M		12V20W (7983) Bulb	\$ 5.00
210971-M		12V35W (7468) Fischer 2 Pole Bulb	\$ 3.10
210969-M		12V25W Bulb	\$ 6.60
211847-M		Socket	\$ 4.60
211006-M		Socket	\$ 4.30
211010-M		Socket	\$ 3.00
010053-M		Cut Button Only	\$20.90
210414-M		Micro Switch GVCF	\$ 7.00
210284-M		Toggle Switch	\$ 7.30
206224-M		Cutting Stick Stop Right	\$ 2.20
206225-M		Cutting Stick Stop Left	\$ 2.20
206293-M		Handle	\$19.60
210262-M		Reverse Switch	\$ 6.80
210611-M		Brush Holder (4x4)	\$ 1.40
210612-M		Carbon Brush (4x4)	\$ 1.40
210610-M		Carbon Brush 10x15x6	\$ 1.40
211098-M		Limit Switch AT11D-2-I	\$30.70
211459-M		24V1.2W Bulb	\$ 3.10
210993-M		24V1.2W Bulb	\$ 1.50
207715-M		12x1232 V Belt	\$14.30
218211-M		10x560 V Belt	\$ 2.80
300009-P		Spare Parts Book	\$ 4.40
300012-P		Inst. Manual	\$ 1.90
209563-M		Piston Oil Pump	\$ 9.70
206579-M		Knife Handle	\$ 3.30
206589-M		Gauge for Mag. Head	\$ 3.30
215227-M		Clutch Handle	\$19.60
010859-M		T Wrench	\$ 9.70
011686-M		Mag Head	\$54.00
217490-M		Mag Tape On Carrier 28x1040 Mag Tape	\$52.00
210413-M	Micro Switch	\$ 6.10	
013752-P	Hydr Oil (Gal)	\$ 4.60	
013753-P	Gear Oil (Qt)	\$ 2.60	
013754-P	Spindle Oil (Qt)	\$ 2.00	
Polar Model #82EL	210385-M	Limit Switch AT 11-2-II	\$19.60

ALL PRICES LISTED ABOVE ARE SUBJECT TO CHANGE WITHOUT NOTICE.

Machine Model	Part Number	Item Description	Unit Price
Polar Model #82EL	010784-M	Plastic Clamp Pressure Pedal	\$13.60
	205208-M	12.5x2150 V Belt	\$21.00
	217884-M	Hydr Hose	\$16.10
	205869-M	Hose Clip	\$ 1.50
	205698-M	Spring for Hydr Hose	\$ 2.80
	210284-M	Toggle Switch	\$ 7.30
	211013-M	ST103 Starter	\$ 2.80
	21098-M	Fluorescent Lamp 13W	\$12.80
	211011-M	Ballast for Fluorescent Lamp	\$19.40
	211001-M	Socket	\$ 2.40
	200962-M	Knife Bolts 10x16	\$ 1.00
	010034-M	Eccentric Handle	\$14.70
	206016-M	Shear Bolt	\$ 4.60
	205525-P	Shear Bolt NWT	\$ 1.70
	206036-M	False Clamp Lock Pin Assembly CPL	\$ 6.10
	206035-M	False Plate Pin	\$ 1.50
	210970-M	12V45W Bulb	\$ 4.20
	211005-M	Socket	\$ 4.30
	215561-M-old style	Short Side Guide Right	\$35.40
	215525-M-new style	Short Side Guide Right	\$37.60
	215166-M	Covering Plate	\$ 4.70
	210293-M	Cut Button AKI-I-Interior	\$20.90
	209368-M	Cutting Stick	\$ 2.50
	206224-M	Cutting Stick Stop Right	\$ 2.20
	206225-M	Cutting Stick Stop Left	\$ 2.20
	206273-M	Toothed Wheel	\$18.70
	010551-M	Oil Pressure Gun	\$ 8.80
	010056-M	Valve	\$ 3.40
	210414-M	Micro Switch GVCF	\$ 7.00
	206293-M	Handle	\$19.60
	210262-M	Reverse Switch	\$ 6.80
	210611-M	Brush Holder (4x4)	\$ 1.40
	210612-M	Carbon Brush (4x4)	\$ 1.40
	206286-M	Clutch Pinion Bear.	\$11.60
	205178-M	10x950 V Belt	\$ 3.10
	010060-M	Brake Ring	\$42.00
	010063-M	Brake Ring	\$42.00
	210972-M	12V45W Bulb	\$ 6.90
	211005-M	Socket	\$ 4.30
	206347-M	Screen - White	\$ 7.90
	209362-M	Screen - Green	\$ 7.90
	011778-M	Mag Head	\$54.00
	013726-M	Cam	\$12.20
	210386-M	Limit Switch AT21-6-I	\$28.40
	010115-M	T Wrench	\$11.90
	206579-M	Handle	\$ 3.30
	010699-M	Knife Gauge	\$10.10
	205336-M	Grease Gun	\$16.20
	010958-M	Clutch Handle	\$ 9.40
	010660-M	Holder	\$ 7.00

ALL PRICES LISTED ABOVE ARE SUBJECT TO CHANGE WITHOUT NOTICE.

Machine Model	Part Number	Item Description	Unit Price
Polar Model #82EL	206589-M	Gauge for Mag Heads	\$ 3.30
	329825-M	Spare Parts Book	\$ 9.40
	329822-P	Inst. Manual	\$ 7.50
	013752-P	Hydr. Oil (Gal)	\$ 4.60
	013753-P	Gear Oil (Qt)	\$ 2.60
Polar Model #90EL	013754-P	Spindle Oil (Qt)	\$ 2.00
	010784-M	Plastic Clamp Pressure Pedal	\$13.60
	205218-M	16x2120 V Belt	\$23.70
	217884-M	Hydr Hose	\$16.10
	205869-M	Hose Clip	\$ 1.50
	205698-M	Spring for Hydr Hose	\$ 2.80
	205912-M	Link	\$ 9.20
	210284-M	Toggle Switch	\$ 7.30
	211013-M	ST103 Starter	\$ 2.80
	210982-M	Fluorescent Lamp 13W	\$12.80
	211001-M	Socket	\$ 2.40
	211011-M	Ballast for Fluorescent Lamp	\$19.40
	210987-M	12V1.2W Bulb	\$ 1.50
	210986-M	12V1.2W Bulb-White	\$ 3.10
	200962-M	Knife Bolts 10x16	\$ 1.00
	010034-M	Eccentric Handle	\$14.70
	206016-M	Shear Bolt	\$ 4.60
	205525-P	Shear Bolt NWT	\$ 1.70
	206036-M	False Clamp Lock Pin Assembly CPL	\$ 6.10
	206035-M	False Plate Pin	\$ 1.50
	210962-M	6V5W Bulb	\$ 7.30
	210985-M	6V1.2W Bulb	\$ 3.10
	211009-M	Socket	\$ 2.30
	210890-M	Photo Element	\$20.40
	210970-M	12V35W Bulb	\$ 4.20
	211005-M	Socket	\$ 4.30
	206200-M	Short Side Guide Right	\$37.60
	010053-M	Cut Button Only	\$20.90
	210414-M	Micro Switch GVCF	\$ 7.00
	206618-M	Cutting Stick	\$ 2.50
	206224-M	Cutting Stick Stop Right	\$ 2.20
	206225-M	Cutting Stick Stop Left	\$ 2.20
	206273-M	Toothed Wheel	\$18.70
	010551-M	Oil Pressure Gun	\$ 8.80
	010056-M	Valve	\$ 3.40
	206293-M	Handle	\$19.60
	210262-M	Reverse Switch	\$ 6.80
210611-M	Brush Holder (4x4)	\$ 1.40	
210612-M	Carbon Brush (4x4)	\$ 1.40	
206286-M	Clutch Pinion Bear	\$11.60	
010060-M	Brake Ring	\$42.00	
010063-M	Brake Ring	\$42.00	
205178-M	10x950 V Belt	\$ 3.10	
210972-M	12V45W Bulb	\$ 6.90	
211005-M	Socket	\$ 4.30	

ALL PRICES LISTED ABOVE ARE SUBJECT TO CHANGE WITHOUT NOTICE.

Machine Model	Part Number	Item Description	Unit Price
Polar Model #90EL	208683-M	Screen	\$ 7.90
	210414-M	Micro Switch GVCF	\$ 7.00
	011778-M	Mag Head	\$54.00
	013726-M	Cam	\$12.20
	210386-M	Limit Switch AT21-6-I	\$28.40
	010115-M	T Wrench	\$11.90
	206579-M	Handle	\$ 3.30
	010699-M	Knife Gauge	\$10.10
	209563-M	Piston Oil Pump	\$ 9.70
	010113-M	Knife Holder	\$13.70
	010958-M	Clutch Handles	\$ 9.40
	206589-M	Gauge for Mag Heads	\$ 3.30
	359996-P	Spare Parts Book	\$ 8.50
	359995-P	Inst. Manual	\$ 7.50
	013752-P	Hydr Oil	\$ 4.60
	013753-P	Gear Oil	\$ 2.60
	013754-P	Spindle Oil	\$ 2.00
	211098-M	Limit Switch AT11D-2-I	\$30.70
	010784-M	Plastic Clamp Pressure Pedal	\$13.60
	217884-M	Hydr Hose	\$16.10
	205869-M	Hose Clip	\$ 1.50
	205698-M	Spring for Hydr Hose	\$ 2.80
	205912-M	Link	\$ 9.20
	210284-M	Toggle Switch	\$ 7.30
	211013-M	ST103 Starter	\$ 2.80
	210982-M	Fluorescent Lamp 13W	\$12.80
	211001-M	Socket	\$ 2.40
	211002-M	Socket	\$ 3.50
	211011-M	13W Ballast for Fluor. Lamp	\$19.40
	200962-M	Knife Bolt 10x16	\$ 1.00
	010034-M	Eccentric Handle	\$14.70
	206016-M	Shear Bolt	\$ 4.60
	205525-P	Shear Bolt Nut	\$ 1.70
	206036-M	False Clamp Lock Pin Assembly CPL	\$ 6.10
	206035-M	False Plate Pin	\$ 1.50
	210962-M	6V5W Bulb	\$ 7.30
	210991-M	24V1.5 Raffi Bulb	\$ 1.50
	210971-M	12V35W Fischer 2 Pole Bulb	\$ 3.10
	211006-M	Socket	\$ 4.30
	206200-M	Short Side Guide Right	\$37.60
	211459-M (210994)	24V1.2W Bulb	\$ 3.10
	210993-M	24V1.2W Bulb	\$ 1.50
	010053-M	Cut Button Only	\$20.90
	210414-M	Micro Switch GVCF	\$ 7.00
	206618-M	Cutting Stick	\$ 2.50
	206624-M	Cutting Stick Stop Right	\$ 2.20
	206625-M	Cutting Stick Stop Left	\$ 2.20
	206273-M	Toothed Wheel	\$18.70
	010551-M	Oil Pressure Gun	\$ 8.80

ALL PRICES LISTED ABOVE ARE SUBJECT TO CHANGE WITHOUT NOTICE.

Machine Model	Part Number	Item Description	Unit Price	
Polar Model #90CE	010056-M	Valve	\$ 3.40	
	206293-M	Handle	\$19.60	
	210262-M	Reverse Switch	\$ 6.80	
	210611-M	Brush Holder (4x4)	\$ 1.40	
	210612-M	Carbon Brush (4x4)	\$ 1.40	
	206286-M	Clutch Pinion Bear	\$11.60	
	010060-M	Brake Ring	\$42.00	
	010063-M	Brake Ring	\$42.00	
	205178-M	10x950 V Belt	\$ 3.10	
	205218-M	16x2120 V Belt	\$23.70	
	210972-M	12V45W Bulb	\$ 6.90	
	211005-M	Socket	\$ 4.30	
	215468-M	Mag Tape On Carrier	\$75.00	
	011778-M	Mag Heads	\$54.00	
	013726-M	Cam	\$12.20	
	010115-M	T Wrench	\$11.90	
	206579-M	Handle	\$ 3.30	
	010699-M	Knife Gauge	\$10.10	
	209563-M	Piston Oil Pump	\$ 9.70	
	010113-M	Knife Holder	\$13.70	
	010958-M	Clutch Handles	\$ 9.40	
	013752-P	Hydr Oil (Gal)	\$ 4.60	
	013753-P	Gear Oil (Qt)	\$ 2.60	
	013754-P	Spindle Oil (Qt)	\$ 2.00	
	206020-M	Support	\$ 3.30	
	206589-M	Mag Head Gauge	\$ 3.30	
	208683-M	Glass Screen	\$ 7.90	
	208684-M	Glass Screen	\$ 7.90	
	359992-P	Spare Parts Book	\$ 4.80	
	359993-P	Inst Manual	\$ 2.10	
	Polar Model #150CE	211098-M	Limit Switch AT11D-2-I	\$30.70
		010784-M	Plastic Clamp Pressure Pedal	\$13.60
		205218-M	16x2120 V Belt	\$23.70
		216626-M	12x1432 V Belt	\$10.30
		217884-M (205909)	Hydr Hose	\$16.10
		205869-M	Hose Clip	\$ 1.50
		205698-M	Spring for Hydr Hose	\$ 2.80
		205912-M	Link	\$ 9.20
		210284-M	Toggle Switch	\$ 7.30
		211013-M	ST103 Starter	\$ 2.80
		210983-M	Fluorescent Lamp 30W	\$ 7.40
		211004-M	Socket	\$ 2.40
		211012-M	30W Ballast	\$19.40
		200292-M	Knife Bolt 10X	\$ .80
		217079-M	Eccentric Handle	\$16.10
		206685-M	Shear Bolt	\$10.00
		205518-M	Shear Bolt Nut	\$ 1.40
206036-M		False Clamp Lock Pin Assembly CPL	\$ 6.10	
206689-M		Plastic Support	\$ 4.20	
206208-M		Pin	\$ 2.10	
206831-M	Pin	\$ .80		

ALL PRICES LISTED ABOVE ARE SUBJECT TO CHANGE WITHOUT NOTICE.

Machine Model	Part Number	Item Description	Unit Price
Polar Model #150CE	210962-M	6V5W Bulb	\$ 7.30
	210991-M	24V1.5 Raffi Bulb	\$ 1.50
	210971-M	12V35 Fischer 2 Pole Bulb	\$ 3.10
	211006-M	Socket	\$ 4.30
	211459-M (210994)	24V1.2W Bulb	\$ 3.10
	210993-M	24V1.2W Bulb	\$ 1.50
	010053-M	Cut Button Only	\$20.90
	210414-M	Micro Switch GVCF	\$ 7.00
	206886-M	Cutting Sticks	\$ 4.60
	206624-M	Cutting Stick Stop Right	\$ 2.20
	206625-M	Cutting Stick Stop Left	\$ 2.20
	206273-M	Toothed Wheel	\$18.70
	010591-M	Pinion	\$ 8.90
	206293-M	Handle	\$19.60
	210262-M	Reverse Switch	\$ 6.80
	210611-M	Brush Holder (4x4)	\$ 1.40
	210612-M	Carbon Brush (4x4)	\$ 1.40
	206286-M	Clutch Pinion Bear	\$11.60
	010063-M	Brake Ring	\$42.00
	205180-M	10x1060 V Belt	\$ 3.50
	010060-M	Brake Ring	\$42.00
	207015-M	Oil Reservoir	\$ 2.50
	207034-M	Screen-Green Top	\$12.50
	210971-M	12V35W Bulb	\$ 3.10
	211006-M	Socket	\$ 4.30
	216745-M	Shift Fork	\$25.40
	011686-M	Mag Head	\$54.00
	010801-M	Air Jet	\$ 1.40
	010800-M	Air Jet	\$ 1.40
	013726-M	Cam	\$12.20
	010119-M	T Wrench 6 M.M.	\$ 8.20
	010120-M	T Wrench 10 M.M.	\$11.20
	010231-M	Clutch Handles	\$16.00
	205335-M	Grease Gun	\$16.00
	207315-M	Knife Handle	\$16.10
	010113-M	Knife Holder	\$13.70
	010659-M	Knife Gauge	\$ 8.90
	010664-M	Knife Stand Left	\$35.40
	010663-M	Knife Stand Right	\$26.60
	013752-P	Hydr Oil (Gal)	\$ 4.60
013753-P	Gear Oil (Qt)	\$ 2.60	
013754-P	Spindle Oil (Qt)	\$ 2.00	

ALL PRICES LISTED ABOVE ARE SUBJECT TO CHANGE WITHOUT NOTICE.

Machine Model	Part Number	Item Description	Unit Price
C-17 (K-44) C-20 (K-52) B20 (T-52)	200-210-111	Scoring Blade	\$ 5.70
	200-210-121	Slitting Blade	\$ 6.00
	200-211-020	Perf. Blade 15 Teeth	\$10.00
	200-211-030	Perf. Blade 10 Teeth	\$10.00
Note: Perf. Blades Also Available With 30, 40, 62, 72 Teeth, Heavy Duty Slitting Blades Also Available.			
B-26 (T-66) C-26 (K-66) B-30 (T-78) C-30 (K-78) B-37 (T-94) C-37 (K-94)	200-210-041	Scoring Blade	\$ 6.50
	200-210-051	Slitting Blade	\$ 6.50
	200-210-061	Perf. Blade 18 Teeth	\$10.00
	200-210-071	Perf. Blade 12 Teeth	\$ 8.00
Note: Perf. Blades Also Available With 8, 15, 24, 30, 36, 40, 48, 60, 72, 80 Teeth--Heavy Duty Slitting Blades With 64, & 69 M.M. Outside Diam. Also Available.			
B-42 (T-107)	200-210-211	Scoring Blade	\$ 6.80
	200-210-231	Slitting Blade	\$ 6.80
	200-210-191	Perf. Blade 30 Teeth	\$ 9.10
	200-210-201	Perf. Blade 18 Teeth	\$ 9.10
Note: Perf. Blades Also Available With 40, 70 Teeth, Heavy Duty Slitting Blades Also Available.			
All Machines With Flat (Pile) Feeder	110-041-210	Rubber Sucker	\$ .40
	110-041-160	Separator Brushes (Set)	\$58.50
	0/650	Drive Belt	\$57.90
	0/700	Drive Belt	\$32.40
	10/800	Drive Belt	\$37.50
	10/850	Drive Belt	\$46.00
	240J8	Poly Belt	\$15.40
	280J8	Poly Belt	\$ 8.25
	300J8	Poly Belt	\$ 7.70
	300J12	Poly Belt	\$16.50
	340J8	Poly Belt	\$21.50
	400J8	Poly Belt	\$18.70
	415J8	Poly Belt	\$21.80
	430J8	Poly Belt	\$22.30
	490J8	Poly Belt	\$24.80
	225xL075	Timing Belt	\$27.20
	240xL050	Timing Belt	\$23.30
	240xL120	Timing Belt	\$33.50
	300L075	Timing Belt	\$15.40
	300L100	Timing Belt	\$35.80
	367L075	Timing Belt	\$37.20
	390L075	Timing Belt	\$16.50
	450L075	Timing Belt	\$38.80

ALL PRICES LISTED ABOVE ARE SUBJECT TO CHANGE WITHOUT NOTICE.

Machine Model	Part Number	Item Description	Unit Price
All Machines With Flat (Pile) Feeder	20x582	Transp (Red) Belt	\$10.60
	20x854	Transp (Red) Belt	\$ 5.70
	20x1055	Transp (Red) Belt	\$13.30
	20x1200	Transp (Red) Belt	\$ 8.20
	20x1280	Transp (Red) Belt	\$14.90
	20x1525	Transp (Red) Belt	\$ 7.50
	20x1760	Transp (Red) Belt	\$17.60
	20x2350	Transp (Red) Belt	\$20.60
	50x1840	Transp (Red) Belt	\$34.70
	50x2305	Transp (Red) Belt	\$39.80
	9.5x700	V Belt	\$ 9.30
	9.5x725	V Belt	\$ 7.00
	9.5x800	V Belt	\$ 7.40
	9.5x850	V Belt	\$ 8.00
	9.5x925	V Belt	\$10.60
	9.5x950	V Belt	\$12.40
	9.5x1000	V Belt	\$ 6.80
	9.5x1675	V Belt	\$17.40
	9.5x2120	V Belt	\$19.40
13x1448	V Belt	\$17.50	
Double Sheet Detector	PJ-S-016	Micro Switch	\$14.20
	PSX-S0-29	Micro Switch	\$12.90
F/KM 80/40 Motor	8x6.3x16.5	Carbon Brush	\$ 3.30
F/KM 87/60 Motor	8x6.2x22.2	Carbon Brush	\$ 3.30
F/KM 94/60 Motor	10x6.2x22.7	Carbon Brush	\$ 5.20
	1.6 AMP 250V	Fine Wire Fuse	\$ 1.40
	2 AMP 250V	Fine Wire Fuse	\$ 1.40
	3.15 AMP 250V	Fine Wire Fuse	\$ 1.50
For Hold-Down Wheel On Round Feeder Machine	F.R.F.	Foam Rubber Strips	\$ .80
For Suction Wheel	115x2.5	Rubber "O" Ring	\$ 1.70
	20 M.M.	Plastic Ball	\$ 1.70
	24 M.M.	Plastic Ball	\$ 1.80
	35 M.M.	Plastic Ball	\$ 4.10
	20 M.M.	Steel Ball	\$ 1.70
	24 M.M.	Steel Ball	\$ 2.00
	35 M.M.	Steel Ball	\$ 4.30

ALL PRICES LISTED ABOVE ARE SUBJECT TO CHANGE WITHOUT NOTICE.

DIT 2

22/12/59

14

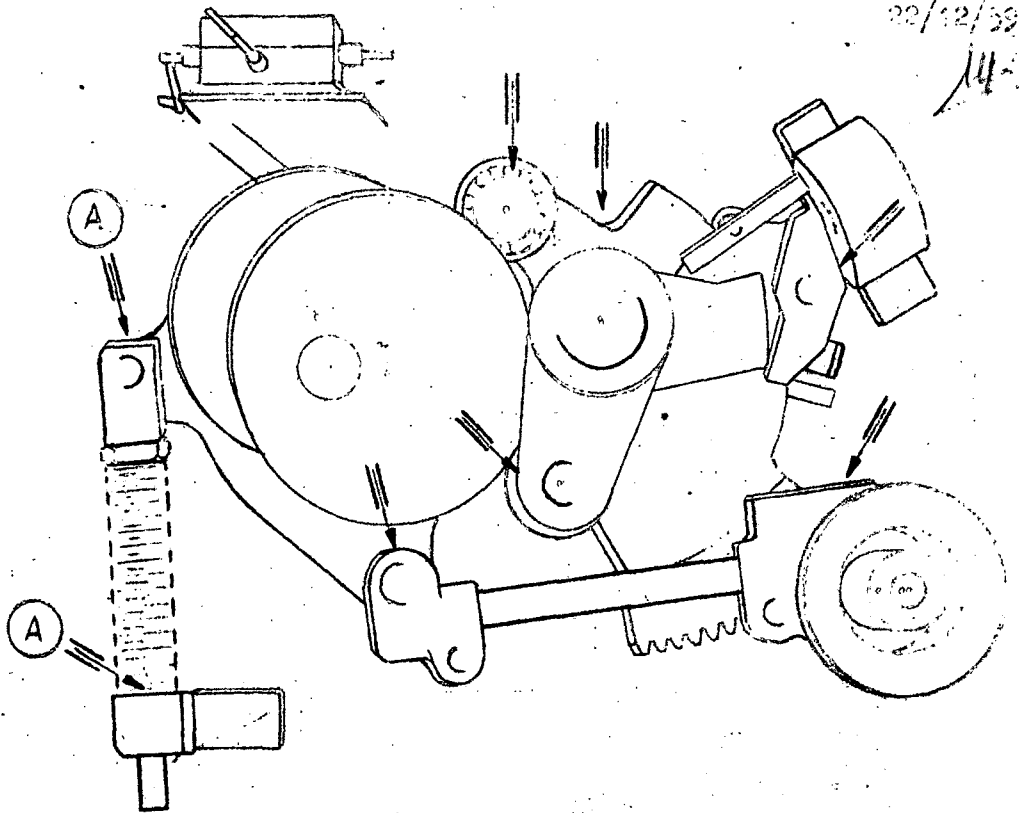

Once a week :

- 1 - Take down the cover.
- 2 - Lubricate all points marked by arrows on the drawing (points marked A only in the RTE and RTU presses). For lubricants to be used see general lubricating instructions on Service Instructions Book.

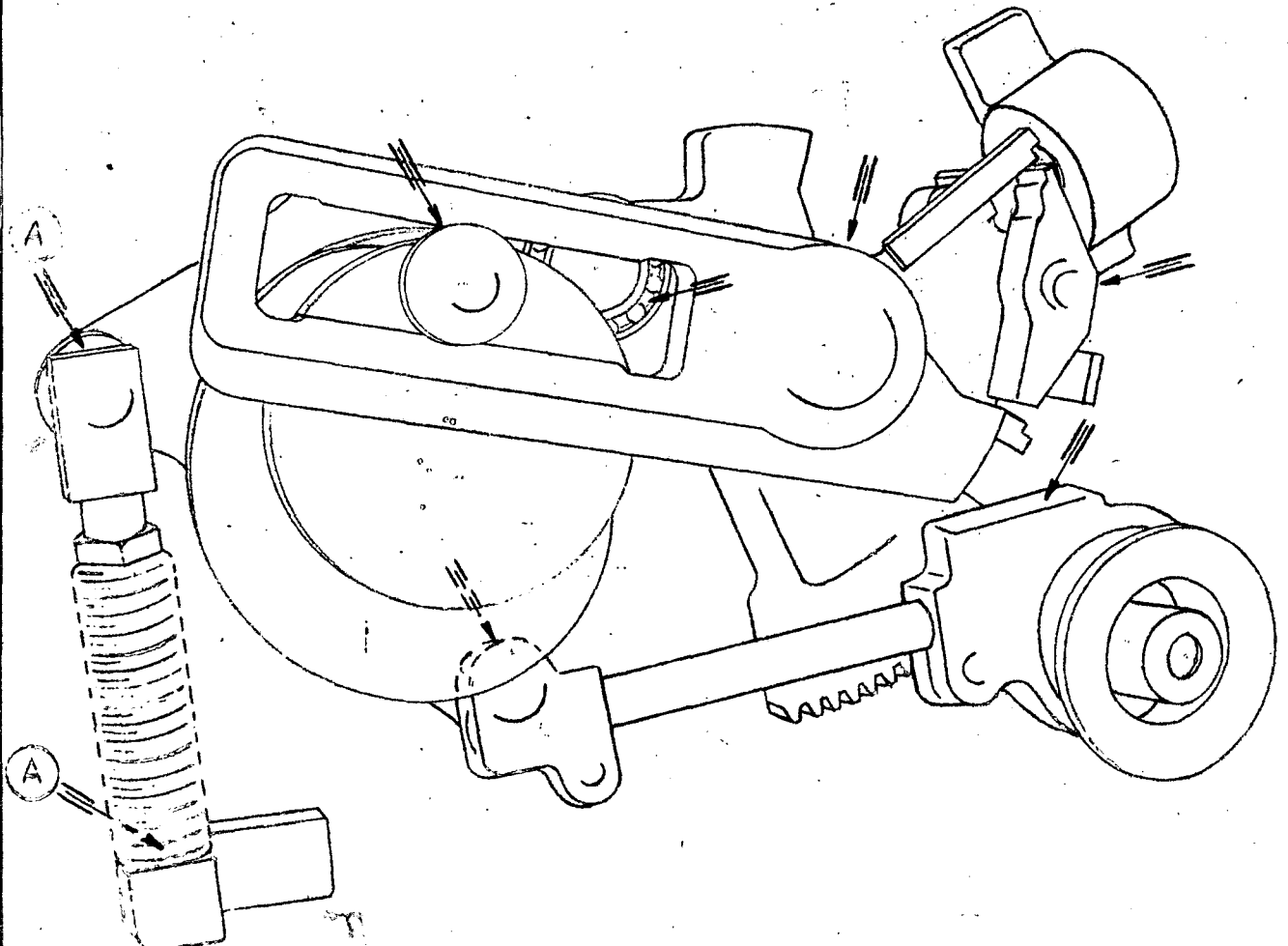

CORRECT POSITION OF THE ATENA DIFFERENT DIAMETER FORME

INKING ROLLERS

All ATENA 196 Letterpresses, starting, from press n. 53470 are equipped with forme inking rollers of different diameter, respectively of 58 - 60 - 63 mm.

The order in which the rollers must be placed is shown on the special plate on the operator's side of the press in correspondence with the forme inking rollers. The plate shows the outline of the three rollers of different diameter with the indication of the respective diameter in both millimeters and inches. The central part of the roller representing the steel core is coloured as follows :

- green for the 63 mm - 2 31/64" - roller
- red for the 60 mm - 2 23/64" - roller
- Yellow for the 58 mm - 2 9/32" - roller

The collars for the roller boxes are painted in the same colour of their respective rollers, to facilitate placing the rollers in correct order.

