

# VANDERCOOK

## DIRECTIONS

Model No. 219

Serial No. 12190



### **VANDERCOOK & SONS, INC.**

*General Offices* — 900 North Kilpatrick Avenue, Chicago 51, Illinois  
*Chicago Display Room* — 1st Floor Transportation Bldg., 630 S. Dearborn  
*Eastern Branch* — 216 East 45th Street, New York 17, N. Y.  
*Western Branch* — 1151 S. Broadway, Los Angeles 15, Calif.

## IMPORTANT INSTRUCTIONS!

Bingham's "Samson" Rollers for Offset and Vulcanized Oil for Letterpress are made of the best materials. They are built to exacting standards for long wear and efficient ink distribution.

- ➔ **Set Rollers Uniformly and Accurately.** Some inks require closer setting than others, but it is always good practice to set rollers as lightly as conditions permit.
- ➔ **Check Setting Frequently.** Improperly set rollers cannot perform to their fullest efficiency. Friction speeds wear.
- ➔ **Keep Rollers Clean.** A roller cannot function efficiently if the surface pores are clogged with dried oils, solvents or gums. Never permit ink to dry on rollers.
- ➔ **Wash Solution for Vulcanized Oil Rollers**—equal parts of high-test gasoline and kerosene. Use clean rags and plenty of solvent, and dry immediately with a soft rag. Rub lightly to avoid scuffing.

### DO NOT USE

Chlorinated Solvents, i.e., Carbon Tetrachloride, Ethylene Dichloride; Hydrocarbon Solvents, i.e., Benzol, Toluol, Xylol; Ketones, i.e., Acetone; Acetates, i.e., Ethyl Acetate, Methyl Acetate Hydrogenated Naphtha; Lye Water, etc.

- ➔ **Storing Rollers:** Store rollers in vertical position, away from heat, sunlight and dust, and free from contact with other surfaces. Avoid rough handling and bumping. Extra rollers should not be stored continuously for more than two months; they will last longer if used occasionally.

### SAM'L BINGHAM'S SON MFG. CO.

*Home Office—Chicago*

Chicago 5, Ill.  
636 Sherman Street

Atlanta 3, Ga.  
274 Trinity Ave., S.W.

Cleveland 14, Ohio  
1432 Hamilton Ave.

Dallas 2, Tex.  
1310 Patterson Ave.

Des Moines 2, Iowa  
1025 W. Fifth St.

Detroit 10, Mich.  
4391 Apple St.

Houston 6, Tex.  
2702 W. Dallas Ave.

Indianapolis 2, Ind.  
629 S. Alabama St.

Kalamazoo 12, Mich.  
223 W. Ransom St.

Kansas City 6, Mo.  
706 Baltimore Ave.

Minneapolis 15, Minn.  
900 S. Third St.

Nashville 3, Tenn.  
911 Berryhill St.

Oklahoma City 6, Okla.  
1213 Linwood St.

Pittsburgh 3, Penn.  
88 S. 13th St.

St. Louis 2, Mo.  
514 Clark Ave.

Springfield, Ohio  
East & Harrison Sts.

**NEW!**

**No. 219**

**VANDERCOOK  
PROOF PRESS**

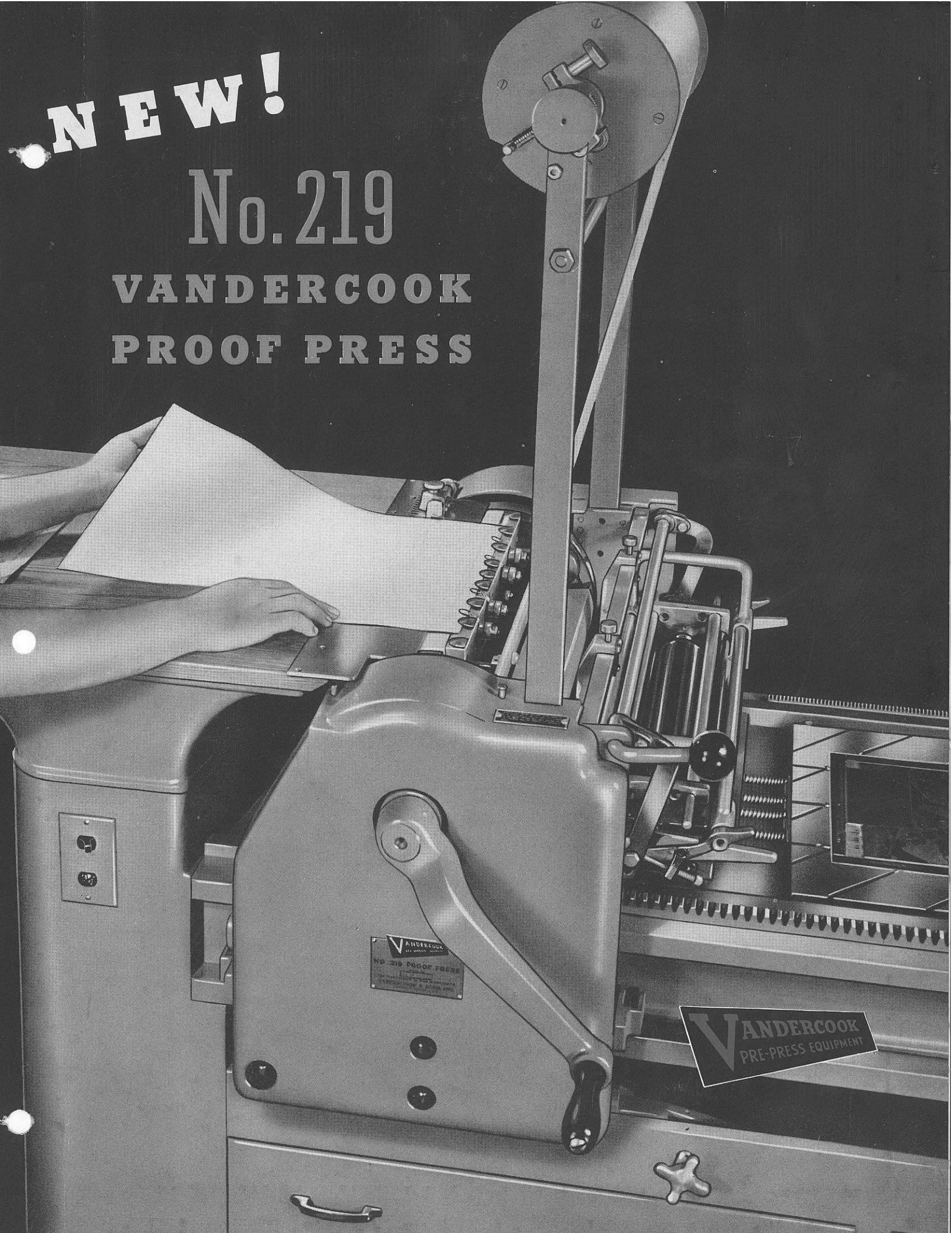

VANDERCOOK  
NO. 219 PROOF PRESS

**VANDERCOOK**  
PRE-PRESS EQUIPMENT

**S**INCE the No. 219 Vandercook Proof Press was first introduced in 1927, it has become recognized almost as standard equipment by photo-engravers throughout the world.

Now, new and improved, the No. 219 Vandercook is even more rugged in construction than the former model, more simplified for easier operation, and capable of even finer results in proving—either black and white, or color.

Equipped with a power driven Ink Drum, the new No. 219 embodies numerous important features which add considerably not only to the proving efficiency of the machine, but save operators' time, labor and effort.

For color proving, a separate inking unit is recommended for each color, since the complete inking unit can be easily lifted from the press in a few seconds for changing colors. Thus, with four inking units, a 4-color plate can be proved without washup, except for the motor driven ink drum and vibrator.

On the opposite pages are illustrated and described the various features to be found in the new No. 219 Vandercook Proof Press — mechanical features which contribute to its simplicity, sturdiness, ease of operation and printing superiority.

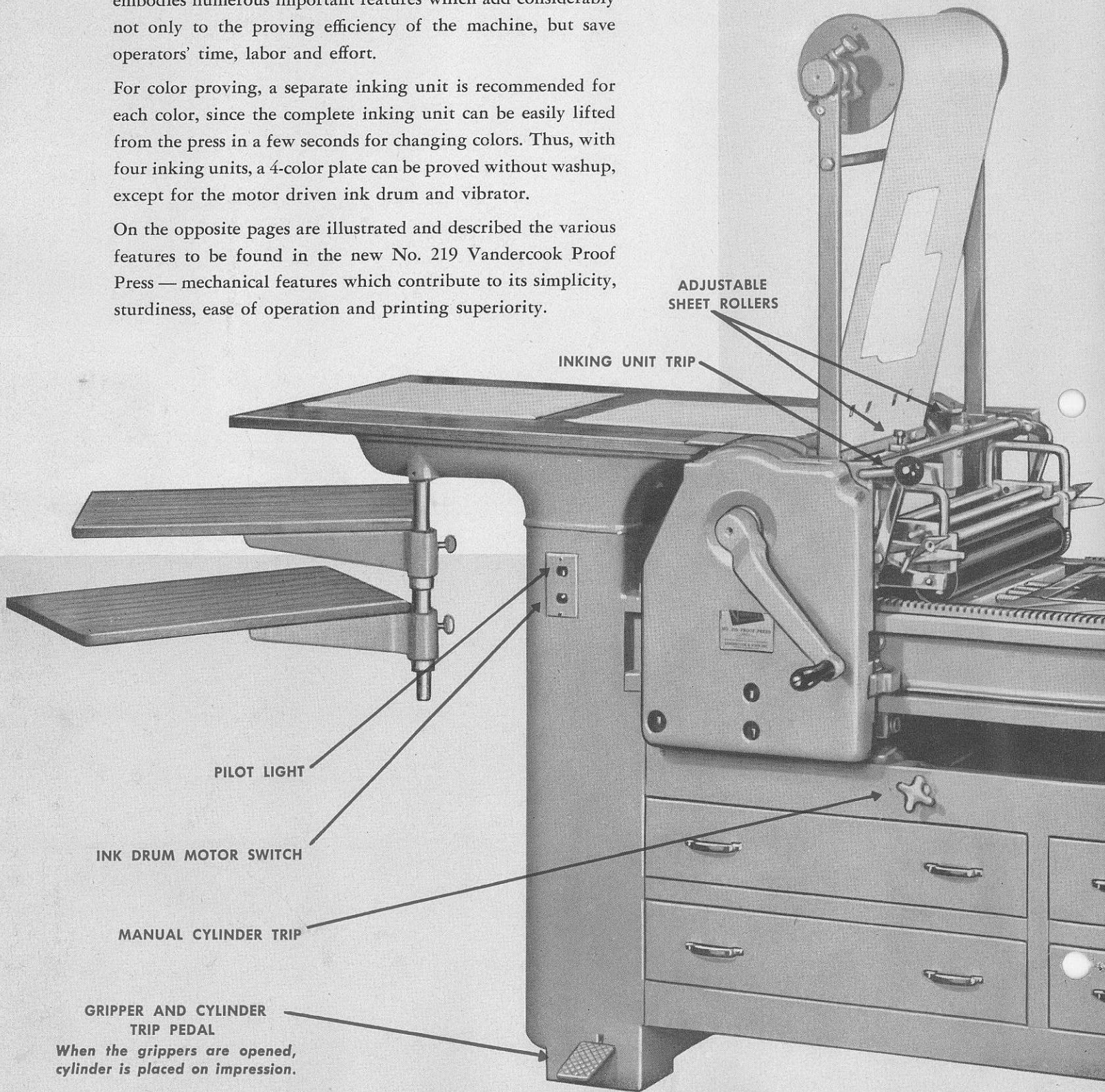

*When the grippers are opened, cylinder is placed on impression.*

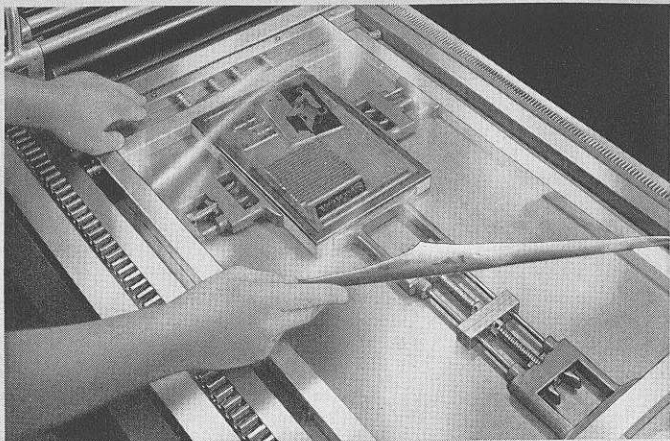

### **Vandercook Register System For Mounted Plates**

With the plate or form locked in a steel chase, as illustrated above, a sheet of celluloid is laid over the form, where it is held in a fixed position by means of projecting pins located on a bar immediately ahead of the deadline of the press bed. An impression is then made on the celluloid from the plate or form.

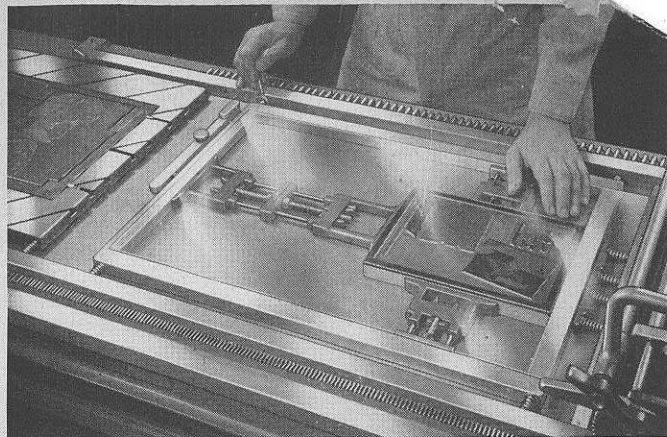

### **Adjusting Chase For Registering Mounted Color Job With Celluloid**

With an impression of the first color on the celluloid, the plate or form for the color to follow is next locked into position in the chase, with the aid of the celluloid held in position by the projecting pins. The entire chase may then be swung into position for closer register, as shown in the illustration above.

### **Control Lever For Lengthening or Shortening Travel of Cylinder**

When this lever is placed in the top hole, which is visible in illustration, the press will print a form or plate up to 25½ inches long; but when the lever is in the lower position, travel of the cylinder carriage is shortened and the press will print up to 20 inches. Experience has shown that the shorter travel is usually long enough for proving the bulk of work in most plants and that a considerable amount of time can be saved by use of this control lever.

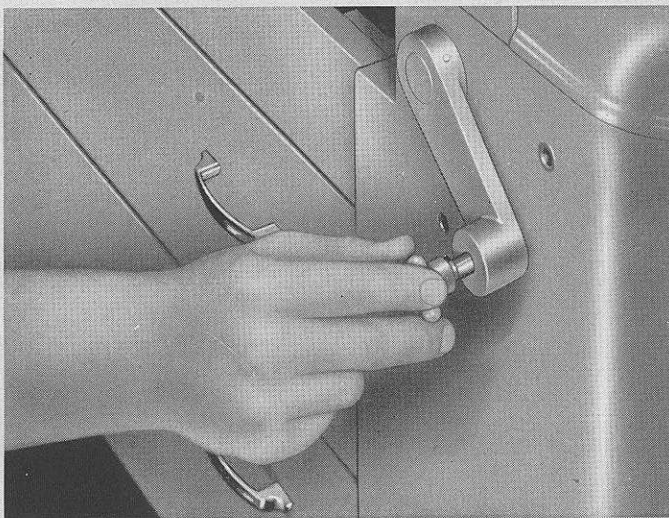

### **Bearer Cleaning System**

This important feature helps to maintain the accuracy of the press. A bronze scraper is kept in constant contact with the cylinder bearers by spring pressure, and felt blocks continually wipe the bed bearers.

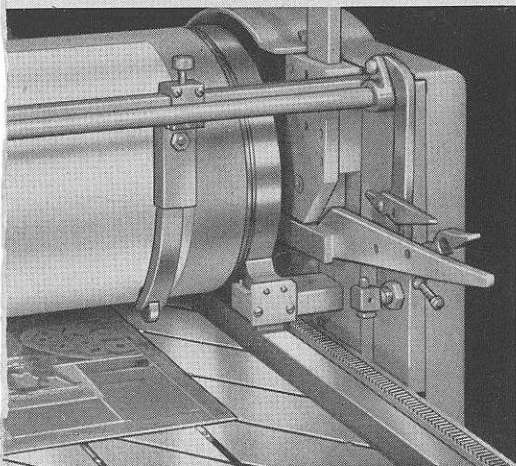

### **Easy Access to Mechanism For Adjustment and Care**

To lubricate the motor or change the belt that drives the ink drum—which can now be accomplished on the No. 219 Vandercook in a matter of seconds—it is necessary only to remove the large panel at the back. Also visible in this view are four ball bearing rollers, running against the rail on the underside of the bed, which permanently keep the cylinder carriage in perfect alignment. This method is also used on the No. 232P Vandercook Power Proof Press.

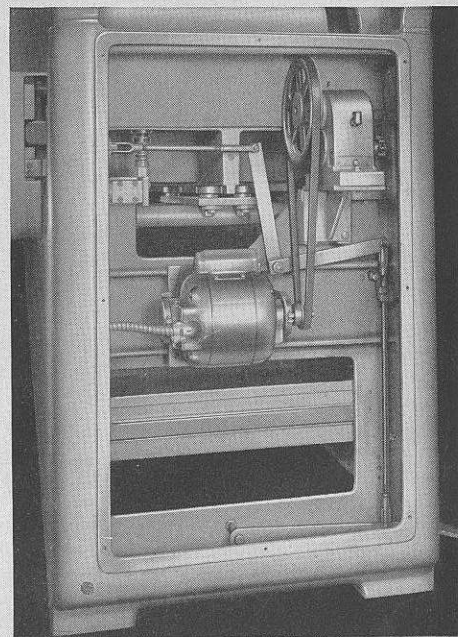

*The New* No. 219

**VANDERCOOK PROOF PRESS**

equipped with Automatic Frisket, Register Plate Base and Power Inking . . . for the finest black and white, or color proofs from mounted or unmounted plates and forms up to 18" x 25½" in size.



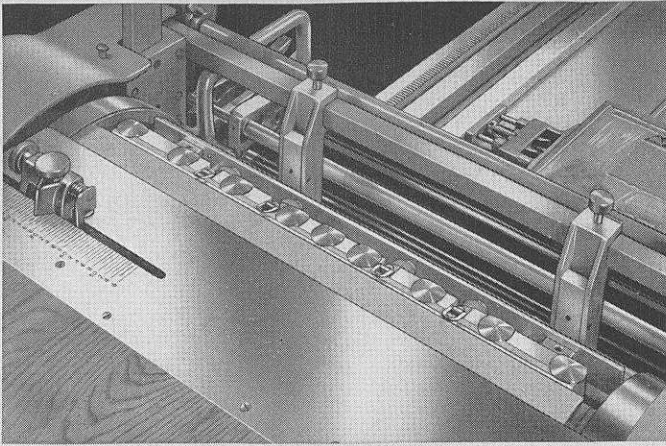

**Foot Operated Grippers and  
Micrometer Sheet Guides**

By depressing the pedal, the grippers are opened for feeding a sheet. To prevent slipping of the sheet, grippers come down on a knurled bar. This knurling, however, does not mark the sheet, merely grips it more firmly. Also visible in above illustration is a rear view of adjustable sheet rollers.

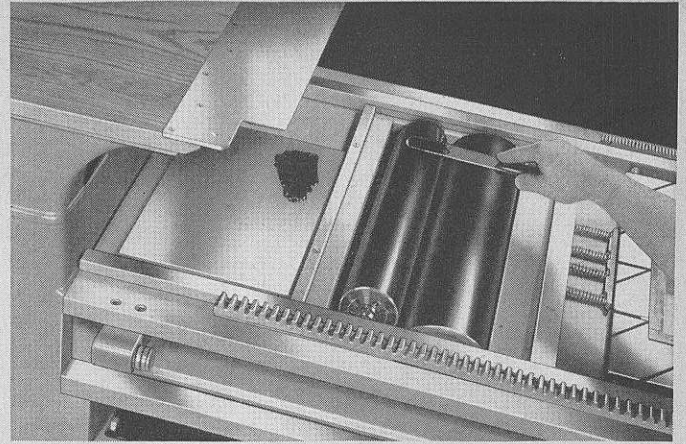

**Vibrator and Motor Driven Ink Drum  
... Also Convenient Ink Plate**

When press is in operation, the vulcanized oil vibrator pulls away and stops as soon as form rollers leave ink drum. Ink is applied with an ink knife, from a convenient ink plate, to the vibrator—which automatically contacts ink drum to supply fresh ink while sheet is being fed.

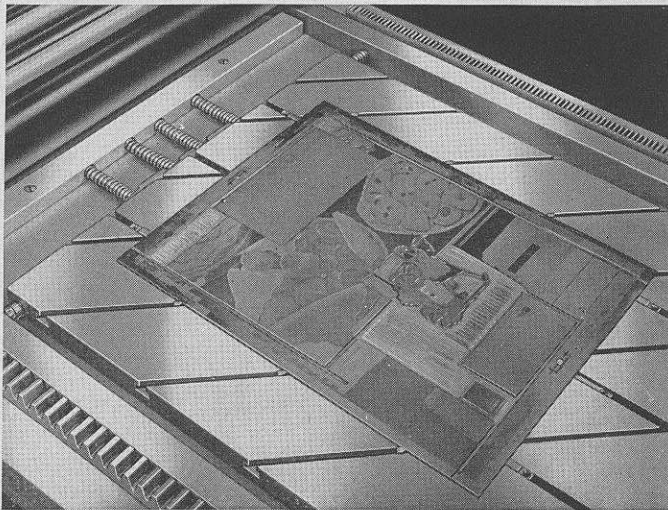

**Vandercook  
Register Plate Base  
For Automatic Register**

To hold plates firmly on base, 3/16" holes are punched through the center of register marks at top and bottom, then placed on the base, with one punched hole over an adjustable head pin in center of the base, and the other hole over a movable tail pin. Special clamps are provided to hold down warped plates, and micrometer adjusting screws for shifting the plate base when registering one or more presses, or correcting for inaccurate punching of plates.

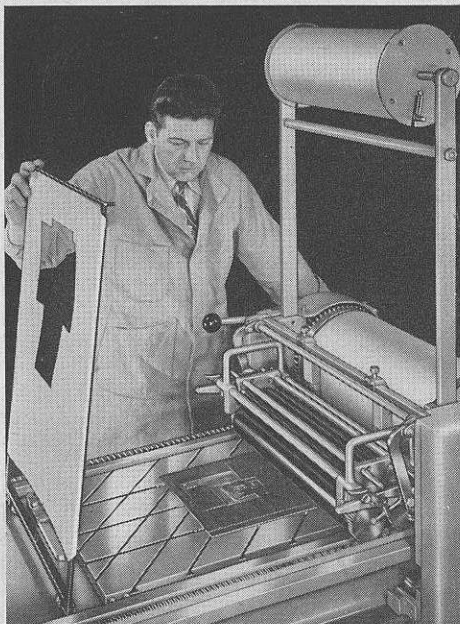

**Choice of  
Hand or Automatic Frisket**

Though either type is available, the automatic is preferred. With it, the frisket web feeds between inking system and impression cylinder, and allows plate to be inked immediately ahead of the impression. It also acts as an automatic sheet delivery, returning the proof back to the feed board printed side up—a great time saver on longer runs. With the hand frisket, plate must be inked in a separate operation, which allows ink to set too long on the plate.

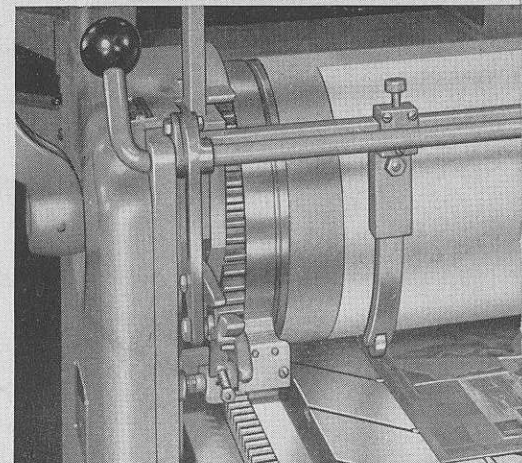

**Adjustable Sheet Rollers**

For maintaining accurate register, and preventing wrinkles or buckles, these adjustable rollers have been found extremely valuable. They engage the margin of the sheet and hold it tightly against the cylinder.

# No. 219 VANDERCOOK PROOF PRESS



## SPECIFICATIONS

Bed Size 19" x 42½" . . . Maximum Sheet 18¾" x 28" . . . Maximum Plate or Form 18" x 25½" . . . Floor Space 3' x 10' . . . Net Weight 2400 Lbs. . . . Crated Shipping Weight 2800 Lbs.

## STANDARD EQUIPMENT

Steel Cabinet under Bed equipped with four Drawers . . . One Inking Unit complete with Synthetic Form Rollers and Extra Roller Stocks . . . ¼ h.p. AC or DC Motor for driving Ink Drum . . . .040" all hard Cylinder Packing . . . 25 Die Cut Drawsheets . . . 25 Die Cut Undersheets . . . Head Dead Line Bar . . . Makeready Table attached to end of Bed . . . Chromium Plated Ink Mixing Plate . . . Necessary Tools.

For use by photo-engravers, press is supplied with a device for quickly locking Vandercook Register Plate Bases and Chases on the bed. For other uses, press is supplied with a Quick Acting Positive Lockup Bar arranged for four positions on the bed. On presses equipped with the Positive Lockup Bar, the Makeready Table attached to the end of the bed is lowered ⅛" to act as a galley rest for sliding forms on and off the bed.

## OPTIONAL EQUIPMENT

Time Saving Frisket Frame . . . Register Plate Base with Springs for use with Vandercook Register Punch, Micrometer Adjusting Screws, 2 Head Plate Pins, 2 Foot Plate Pins, 12 Plate Clamps for Diagonal Slots, 8 Plate Clamps for Straight Slots, 3 Long Slot Fillers, 3 Short Slot Fillers and Necessary Tools . . . Automatic Frisket . . . Extra Inking Unit with Synthetic Form Rollers and Extra Roller Stocks complete with Steel Distributors . . . Steel Cabinet accommodating two Inking Units . . . Steel Stand for Inking Unit Cabinets . . . Register System for Mounted Plates with Celluloid Register Punch; Chase equipped with Springs and Adjusting Screws, one each 1½", 2", 3", 4" and 5" Quick-Acting Job Locks, and Necessary Tools . . . Vandercook Celluloid Register Punch (included with Register System for Mounted Plates.)

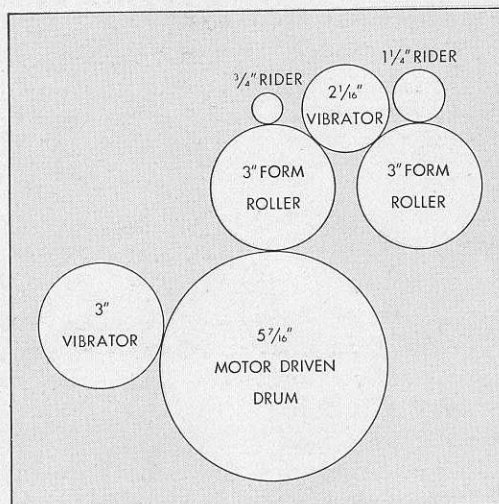

*Diagram of the Efficient Power Operated Inking System of the new No. 219 Vandercook Proof Press.*

## POWER DRIVEN INKING

Consists of a motor driven ink drum, one vulcanized oil vibrating roller, one steel vibrator, two form rollers, and two steel riders. Ink is first applied to vulcanized oil vibrating roller, which transfers it to motor driven ink drum for distribution.

**VANDERCOOK & SONS, INC.**

General Offices — 900 N. Kilpatrick Ave., Chicago 51, Illinois



Chicago Display Room — 630 South Dearborn Street  
Eastern Branch—216 East 45th Street, New York 17, New York  
Western Branch—1151 S. Broadway, Los Angeles 15, California

## DIRECTIONS FOR NO. 219 VANDERCOOK PROOF PRESS

1. Keep Press clean - particularly cylinder and bed bearers.
2. Carry correct amount of cylinder packing and keep it in good condition.
3. Clean inking rollers thoroughly and keep them adjusted.
4. Keep press well lubricated.

### Installation

Place the press on a firm foundation. Clean shipping grease from the bed and other bright parts. Lay a spirit level on the bed and level the bed by means of shims under the four corners of the base. Wood shingles make effective shims for this purpose.

### Lubrication

Fill all oil holes and cups with S.A.E. 20 Motor Oil. Lubricate vibrator worm on inking system with vaseline. All other bearings are either ball bearings packed in grease or oil impregnated wood bearings that require no attention. Press should be thoroughly oiled once a week or every 50 hours of operation.

### Cylinder Trip

On the new model No. 219 machine, the Cylinder Trip and Gripper Opening Foot Pedals have been combined. The cylinder will always be tripped until the grippers are opened to feed a sheet. If it is desired to trip the cylinder after a sheet has been fed, use the Manual Cylinder Trip indicated on page two of the attached bulletin.

### Adjustable Cylinder Travel

A lever is provided near the open end of the press to adjust the cylinder travel. With the lever in the top position, forms or plates up to 25-1/2" long may be printed. With the lever in the lower position, the cylinder travel is shortened and the press will print up to 20". The gripper opening cam on the side of the bed away from the operator has two positions to accommodate the long and short travel. A slight pull will remove the cam.

### To Add Ink

See illustrated instructions on page three of the attached bulletin.

### Operation

When the press is not in use, the motor driven ink drum should always be turned off and the inking system tripped. When the inking system is tripped, the form rollers are free of all contact with the steel distributors. Some provers believe that the ink will dry more slowly if the inking system is kept in operation on the ink drum. Just the reverse is true; the ink will dry much faster if the rollers are kept turning and the entire inking system is subjected to needless wear. The end sheet guide, nearest the side guide, should always be a trifle in advance of the end guide nearest the operator. This is to prevent misregister because of the sheet dragging against the side guide. When feeding the sheet, the grippers are opened by means of a foot pedal, which makes it easy to maintain accurate register. The grippers open automatically when the cylinder is at the other end of the press, to permit removal of the sheet. The sheet rollers provided should be adjusted so that they run on the margins of the sheet. These sheet rollers are set at a slight angle so that they will be more effective in holding the sheet tight to the tympan in order to avoid wrinkling and slurs.

### Cylinder Packing

The cylinder cut is .040". It is very important that the correct amount of packing is carried on the cylinder. Incorrect packing is apt to cause misregister, slurs and wrinkles. Over packing will cause the cylinder to print longer than the form and under packing shorter. The cylinder packing plus the sheet to be printed should be from .002" to .003" over the cylinder bearers. This can be checked with a straight edge. For most work the best cylinder packing consists of all hard manila sheets. Thickness of packing may be adjusted by placing thin sheets next to the cylinder. To change or adjust packing, move cylinder to center of bed (on trip if there is a form or plate on the bed) so that the reel rod is in the up position. Unlatch reel rod ratchet with wrench provided and loosen drawsheet from reel. With left hand grasp packing and as cylinder is returned to feed board, lay packing on feed board. If necessary to change the drawsheet loosen the fillister head screws in the packing clamp gripper bar. Unless overlays are being used only the drawsheet is held by this bar. When moving cylinder to center of bed to secure packing, hold packing in position by smoothing it out with left hand. Be sure packing is tight to cylinder at both sides of gripper edge.

### Makeready

The bed bearers on the No. 219 Vandercook Proving Machine are type high, .918". The Vandercook Register Plate Base for original photo-engravings is .838" thick. Sixteen gauge originals are approximately .0625" thick. .838" plus .0625" equals .9005" which is .0175" short of type high and represents the approximate amount of underlay that must be used. To prove an original with dead metal, lay the plate, loose, on two underlay sheets of combined thickness to bring plate up to slightly less than type high. Take a proof on the stock to be used. The two underlay sheets should be of the correct total thickness to correctly print the highlights.

(Continued on page 3)

Examine the proof with a glass to make sure the highlights are neither punching or breaking. A .005" sheet and a .010" sheet will usually be about right. Next take two proofs, one each on stock identical with the two sheets under the plate. Holes for the plate pins are cut in the lighter sheet to locate this base sheet under the plate. The entire subject is cut out of the heavier sheet and this is pasted in register on the base sheet to act as a relief for the frisket. The solids and middle-tones are built up as required with thin patches (usually .002" to .005"). Because of the stiffness of the plate the patches should be somewhat smaller than the area to be affected. Small detail is, of course, impossible to control with underlay. Some vignettes require an overlay that may be registered on the cylinder packing or may be fed with the sheet to be printed by dropping out one or two tympan sheets. Relief underlay is impossible on wood mounted plates and it is sometimes necessary to use overlays to prove them properly. If an overlay is not required, mounted plates may be proved without locking them on the bed.

#### Adjusting Form Rollers

Run the cylinder to the open end of the bed and remove the steel distributors. Slide the Vandercook "Nuway" Roller Setting Gauge under the inked rollers near the edges. An ink mark on the gauge 1/16" wide indicates when the rollers are correctly adjusted. To adjust rollers, loosen both center set screws at each end of the carriage. Turning the large flat head screws clockwise raises the roller and counter-clockwise lowers the roller. After adjusting both rollers to the correct height, tighten both set screws. The steel distributors require no adjustment.

If you have any questions in regard to the operation of this press, not covered by the directions, write: VANDERCOOK & SONS, INC., 900 NORTH KILPATRICK AVENUE, CHICAGO 51, ILLINOIS

**No. 604 Vandercook 4-Color High Speed Proof Press  
Installed July 9, 1947, Chicago Plant, Foote, Cone & Belding, Inc.**

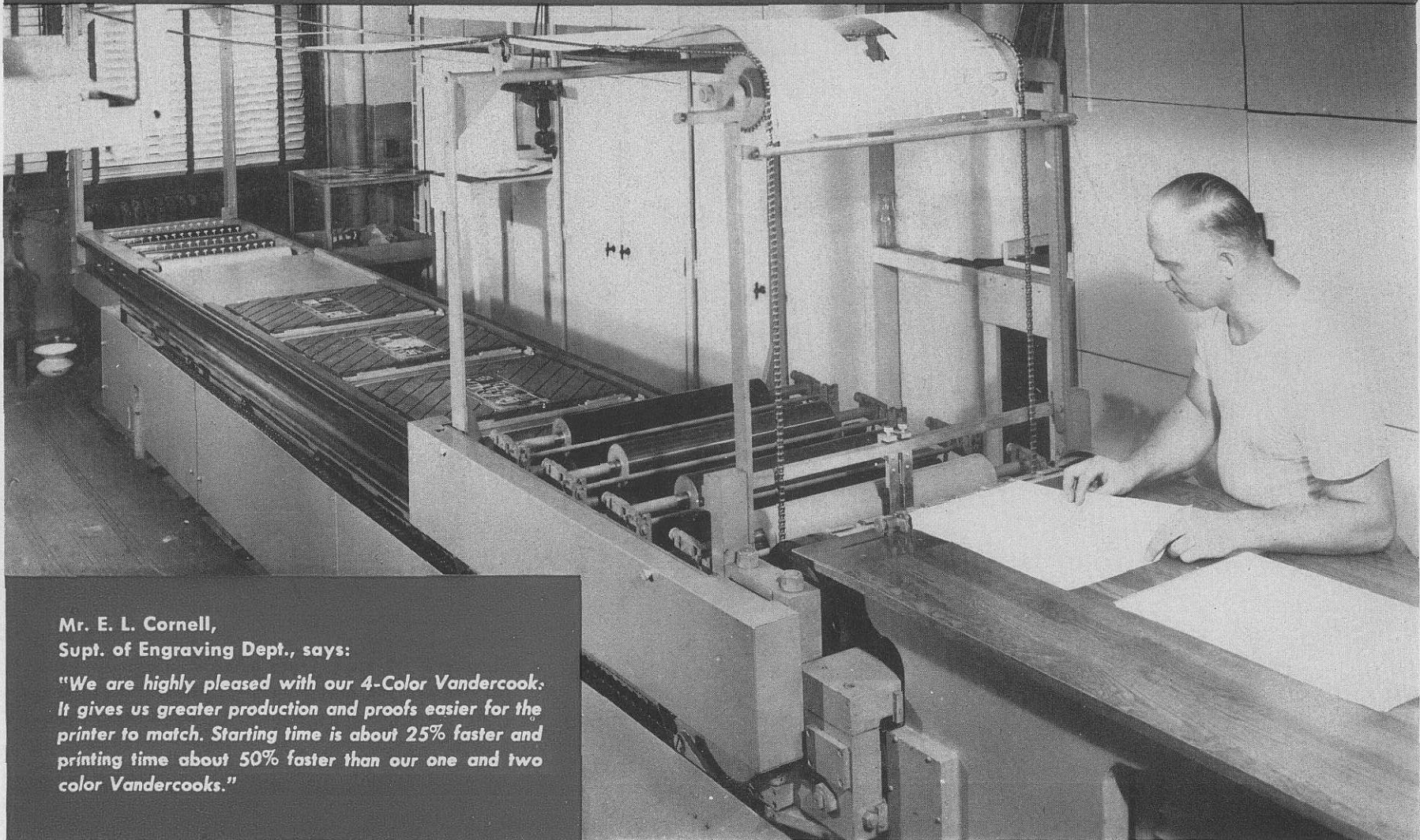

**Mr. E. L. Cornell,  
Supt. of Engraving Dept., says:**

*"We are highly pleased with our 4-Color Vandercook. It gives us greater production and proofs easier for the printer to match. Starting time is about 25% faster and printing time about 50% faster than our one and two color Vandercooks."*

Reprinted From  
November 1947 Issue — Photo Engravers Bulletin