

OPERATING
AND
ADJUSTING
BABCOCK
TWO REVOLUTION
PRESSES

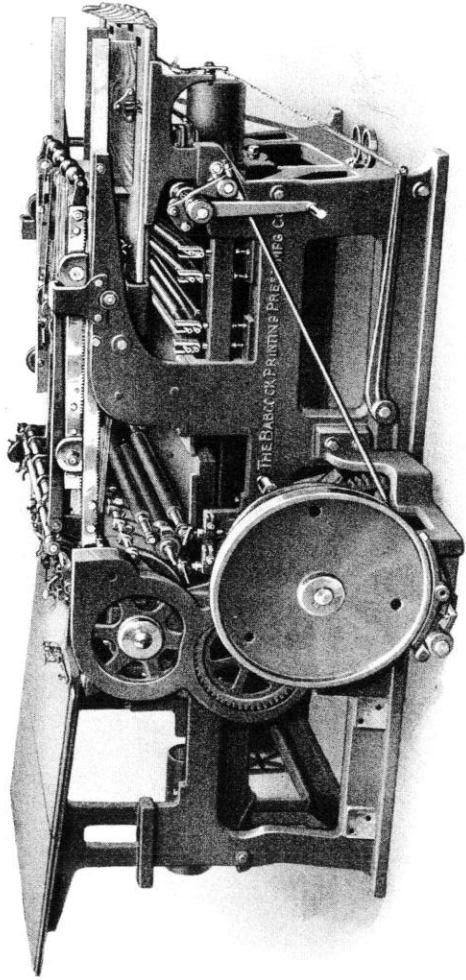

NO. 35 OPTIMUS. Plate No. 3

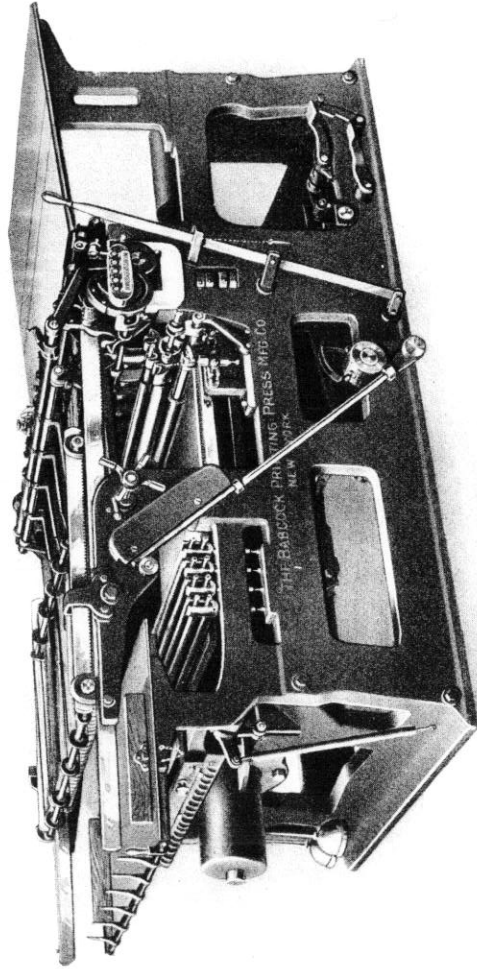

NO. 35 OPTIMUS. Plate No. 4

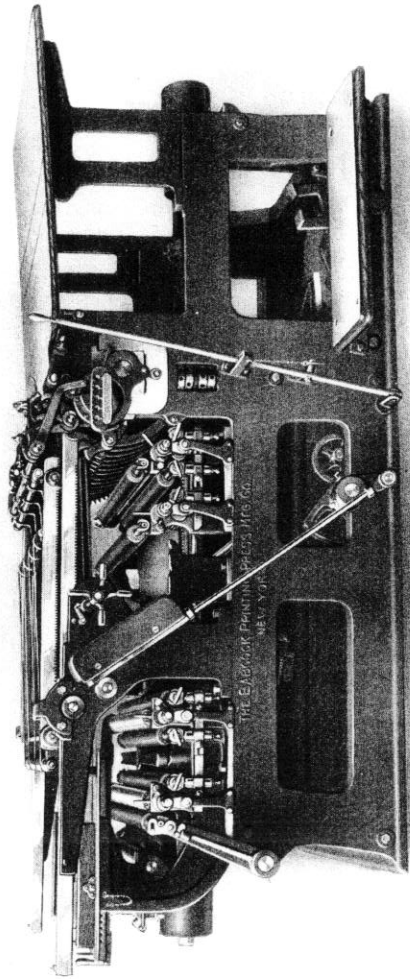

Plate No. 5
No. 41 (two-roller) and No. 43 (three-roller) OPTIMUS

GENERAL INFORMATION

Numbering

The part numbers in this book are the same as those in the booklet, "Parts of the No. 5-12 Four-Roller Optimus Presses," and all parts mentioned in these instructions are shown in that booklet. Wherever a number is used, which is not found on any of the accompanying plates, the part referred to is shown in the "Book of Parts" only. In every case consulting both books will aid in recognizing parts.

Numbers preceded by "O" will be found only in the book of parts for the No. 35, No. 43 Optimus presses. These numbers only need to be used when adjusting those presses.

This numbering does not refer to the numbers which are stamped or cast upon parts. Many of the parts have numerals or marks stamped upon them to correspond with similar numerals or marks stamped upon the parts to which they are to be attached and which determine their location. Particular attention must be paid to them in attaching every part.

Terms Feeder and Gear Side

The feeder side of the press is shown on Plate No. 2. It is the side having the mechanism for driving the ink rolls. The gear side of the press carries the driving pulleys and gears and is shown on Plate No. 1.

Terms Front and Rear

The front end of the press is that section shown on Plate No. 6. It is the end at which the sheet is delivered. See also Plates No. 1 and 2.

The rear end is the one from which the sheet is fed and is that section shown at the left on Plate No. 1. See also Plate No. 2.

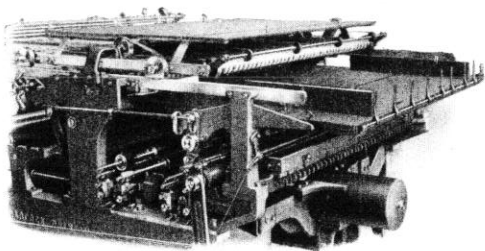

Plate No. 6

Leveling

Leveling is probably the most important factor entering into the care of flat bed presses. Almost anything can happen when the press is "out of level," and it should always be tested "for level" before making important adjustments.

Leveling front to back on the frames where the roller rest brackets go is more important than crosswise leveling, but it is best to level crosswise as well.

As soon as the frames, girts and tracks are in position, and with the bolts set up only friction tight, level carefully both lengthwise and crosswise.

Level on top of the frames about where the roller rest brackets go, preferably, but, if for any

reason, this is not convenient, it will do very nicely to level on the top of the outside rail of the track for the lengthwise test. Use a straight edge placed across the top rails of the track for the crosswise test.

CAUTION.—*Don't ever try to level anywhere else.*

Neither the level nor the straight-edge should ever be turned end for end, and the straight-edge should never be turned over. Mark one end of both the level and the straight-edge. Mark the position of the level on the straight-edge, then always keep the level in this marked position, and keep the marked end of each toward the same end or side of the press.

When leveling the press, use heavy paper or card board, under the frames, or shingles may be driven under the frames from opposite sides of each frame; one shingle on top of the other, thus acting as parallel wedges. This wedging should extend the full length of each side frame. Care should be exercised that the weight is sustained equally at all points, EXCEPT:

It is particularly important that the bearing should not be too heavy under the middle sections of the frames, as this would cause the press to rock.

Caution

The level may change as its temperature changes.

Be sure the level is the same temperature as the room.

Always test for level after final blocking.

Unless the press stands on a solid foundation, it should be tested for level occasionally to see that it is in perfect condition.

If it is found that the floor is settling, it should be given prompt attention and the press wedged up until it is absolutely level again.

Power

The power should be uniformly steady. Use best quality of belting and keep belts properly tight. Care should be exercised, however, not to make the belts too tight, as this consumes power unnecessarily, puts excessive strain on the bearings and causes excessive wear in the loose pulley. It is not possible to make a loose pulley run satisfactorily with a belt that is too tight. A little castor oil applied to new belts is desirable. It increases their driving power and makes them more flexible and durable. Don't put on too much, as that will cause the belt to slip.

Put it on at night so it will work in before morning.

If the Motor Runs Hot

Excessively tight belts are the most common cause for overheating. Other causes are:

Motor too high speed, necessitating very small pulley.

Motor not designed for printing press work.

Motor improperly wired. Press out of level.

Cylinder too hard on the bearers.

Rollers set too hard against the vibrators.

Spiral nuts too tight. Tapes too tight.

ADJUSTMENTS

Wheel Tracks

Nos. 41 to 12 Optimus. Plate No. 7.

Remove all wheels from the tracks, except the wheel which is being adjusted. Loosen the side clamp nuts "B." Back out the set screws "C" and see that the wheel bearing "D" moves up and down freely. Move the bed over the wheel until the wheel is in the middle of the track "E" under the bed, and star gear on top of rack.

Place a piece of moderately thick paper "F" between the wheel and track, and turn down the set screws "C" until the paper just touches the track "E." Then tighten the clamp bolts about one-half tight.

Remove the paper from the top of the wheel, and turn the set screws down, forcing the wheel up squarely until its surface just touches the under side of the track under the bed. Be careful that the wheel only just touches; you should be able to just turn it by hand.

Now tighten the check nuts on the set screws, also the side clamp nuts. Examine the wheel again and see that it only just touches the track under the bed. Then remove this wheel and proceed with the next one in the same manner.

In each case adjust the wheels with the bed in about the same position.

Never attempt to adjust these wheels until after the cylinder is tripped or thrown off; that is, the bed must lie perfectly natural in every way when adjusting the wheel tracks. It will be noticed that each wheel and its bearing is numbered, thus showing where each wheel belongs. The wheels must not be put in the wrong places.

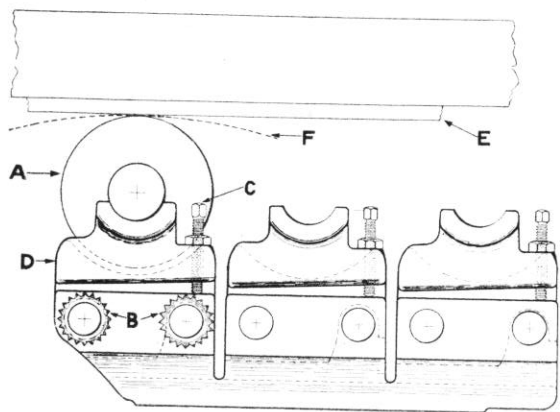

Plate No. 7

Sometimes the bearings will seem to lift slightly when tightening the clamp nuts. In that case, use a piece of thicker paper for the initial operation, or tighten the clamp nuts slightly tighter after this initial operation of setting.

In case the wheel does not bear against the steel clear across its face, set up the screw on the light side tighter.

If the cylinder has been set with the wheel tracks badly out of adjustment, it had better be reset after adjusting the wheels.

NOTE.—Certain of the old models are fitted with "spring adjusted" instead of "screw adjusted" wheels. The method of adjusting is the same, except that the wheel is raised automatically with the spring instead of by means of set screws. After the clamp bolts are set up about one-half tight, remove the paper and set the bolts tight. It is generally necessary to use thin paper between the wheel and bed.

To Adjust the Sliders

Plate No. 8

It will be observed that the spiral bearing 451 has slots in it for the bolts which fasten it to the slider 121. These slots are to admit of adjustment of the sliders with relation to the bed 101. When the press is first set up, fasten bolts in center of these slots. It is best to adjust the sliders every few months so that they will stop in another position. This can be done by simply slacking up the bolts in the spiral bearing 451, and moving the sliders to a new position.

Place blocks of wood of equal length in the tracks between the ends of the sliders 121 and 122, and the caps 112 on the ends of the tracks. Then move the press slowly by hand until the sliders come against this obstruction in the tracks.

The sliders will then stop, but the bed will keep moving. When the new position is secured, simply tighten the bolts in the slots of 451.

NOTE.—Spring bumpers are used on certain models of presses. In this case the spiral is omitted and the sliders adjust themselves automatically.

Spiral Slider Controller

After continuous use the brass spiral nuts or sleeves 470 and 471 are liable to become worn and loose on the spiral 474. To remedy this, loosen the two small set screws and with a wrench turn each half of the brass sleeve (turn one half right-handed and the other half left-handed) until all looseness is taken up, but not so hard as to bind the spiral. Screw the set screws firmly into place again. Now turn the press a full revolution by hand, making sure there is no bind at any point.

Bed Gibs

Plate No. 8

Gibs 516, 517 and 515 should be set so the steel shoe 531 will just touch the sides of the track 123. The rack hanger gibs 235 should be set so they just touch the under side of the track. These gibs have practically nothing to do when the press is new, but after it has been running a number of years and there is looseness in the

tracks, these gibs can be adjusted in such a way as to overcome all looseness.

NOTE.—The gibs and bed have corresponding marks. The latest models of Optimus presses are fitted with gibs only on the feeder side track.

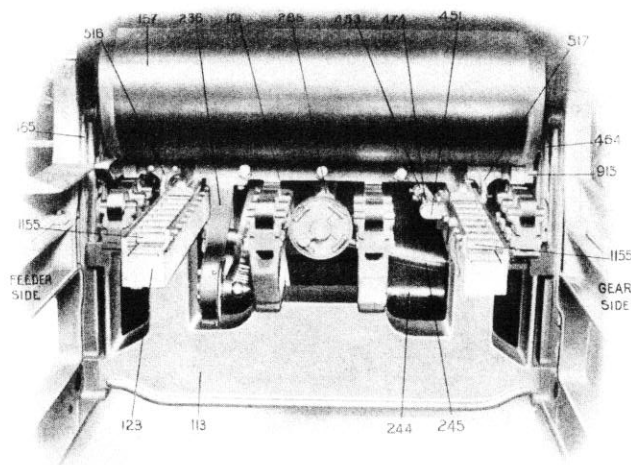

Plate No. 8

Yoke Block

Plate No. 9

The top of the yoke block 227 should be packed with leather until it just touches the top of the slot in the yoke 482 when the rim of the star gear 234 just rests on the rail of the rack 240. The bottom of the slot in the yoke 482 should be correspondingly packed so that the yoke block rests on it when the rim of the gear touches the rail of the rack.

Air Spring

Plates No. 9 and 10

When running the press, great care should be exercised in keeping the air spring in the air chambers 275 and 276, Plates No. 1 and 2, just sufficient to arrest and reverse the type bed 101 without strain on the bed driving mechanism

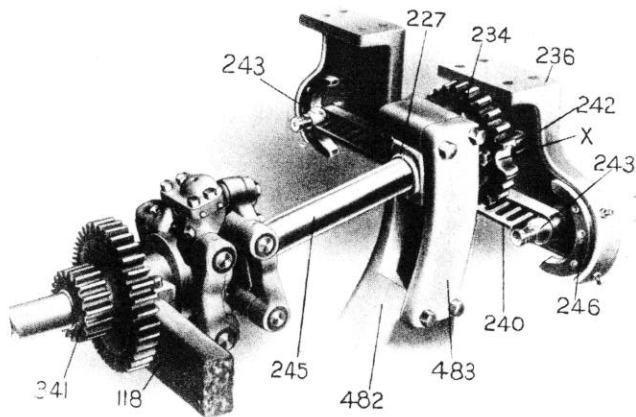

Plate No. 9

The amount of spring is regulated by turning the plunger, Plate No. 10, forward or backward upon the plunger screw. The exact location of the plunger cannot be previously determined, as the requisite amount of spring varies according to the weight of the form, the amount of impression, the quality of the ink and the speed at which press is driven. But, by observing the action of

the machine, the operator can tell whether more or less spring is required.

If the roll 242, Plate No. 9, which is on the side of the star gear 234 and which passes through the shoes 246 when stopping and starting the bed, has a tendency to become warm, it is because there

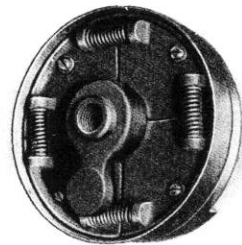

Plate No. 10

is not sufficient pressure in the air chambers, in which case the plunger should be moved nearer to the end of the screw.

If, on the other hand, the star gear shaft 245 and the yoke box bearing 227, Plate No. 9, become warm, it is because the pressure in the chambers is too great. This can be detected by noting the tendency of the balance wheel 355 to slacken its speed a trifle at the time the plunger is in the air chamber while the bed is reversing at the end of the stroke. To remedy this, move the plunger back on the screw one or two turns. In doing this, it should be borne in mind that a little excess of air spring is better than not enough.

In changing the speed of a press, it should be kept in mind that plungers are to be changed also,

moving plunger nearer end of screw for faster and toward center of bed for slower speeds.

Keep the leather well oiled with neat's foot or castor oil. Do not use mineral oil, as it rots and hardens the leather.

If the plunger makes a squeaking noise when entering the air chamber, it is because the leather is dry and needs oil, or because the leather is not sufficiently expanded. The leather is expanded by turning the hand-nut in the center of the plunger a little, as if it were being unscrewed. This allows the springs on the plunger head to expand a little and so expand the leather. It is also desirable to spread out the edge of the leather with the fingers so that the "leading edge," which goes into the air chambers first, will be caught and spread out by the air pressure, thus making the plunger air tight.

Bed Bearers

The bearers 500, Plate No. 13, when screwed to the bed should never be over type high, or not more than .002" under type high; *i. e.*, they should measure between .916" and .918" and should be alike.

If through accident or poor adjustment, there are uneven places in the bearers, it would be well to have them dressed off and a shim of the proper thickness placed underneath. Use hard, firm paper for the shims as soft paper will crush down.

The bearers are always the correct height and perfectly even when shipped from the factory, and need no adjusting.

NOTE.—The back ends of the bearers and bed have corresponding marks.

CAUTION.—*Never underlay the bearers so that they are over type high.*

Never put rosin or other substances on the bearers. If the cylinder is properly adjusted, such things are not needed.

Roller Sockets

Nos. 35, 41 and 43 Optimus. Plate No. 11

Plate No. 11 shows a section of the rear vibrator stand on the feeder's side of the press, with the eccentric roller sockets in position for holding the composition rollers out of contact with the vibrator rollers and form. The form roller socket latches 912, are at one extreme of their throw and lock the rollers in this position. To remove the rollers, the latches stand in an intermediate position.

When the rollers are adjusted, they may be thrown out of action in an instant, or removed entirely from the press without in any way disturbing their set, and may be returned merely by replacing in the sockets and throwing in the latches

It will be seen that the sockets nearest the cylinder are of a different type from the others, as

they open in the opposite direction for the removal of the rollers.

Only the two sockets nearest the cylinder, that is, one on each side of the press, are of this type. They are made in this way so that the composition roller may be removed without interference with the sheet bands. Each socket and its position on the stand is numbered so that no difficulty will be experienced in placing them in their correct positions.

To Set the Rollers

Nos. 35, 41 and 43 Optimus. Plate No. 11

Slightly loosen the nuts 813.

Place the rollers in the sockets and lock them into position for printing by throwing over the latches until they drop into the slots marked "C" and "D."

Adjust the sockets for height by means of the screws "E" so that the rollers just touch and bear evenly the full width of the ink slab, then tighten the check nuts on "E." Do not set the composition rollers too hard upon the slab.

Place the vibrator roller 822 in position, lock the bushing into the stand with button 780, and set up the screw. Now move the sockets so that the composition rollers are in contact with the vibrator roller, and lock them in this position by tightening nuts 813. Do not set the composition rollers against the vibrators any harder than is necessary to secure distribution, as too heavy a

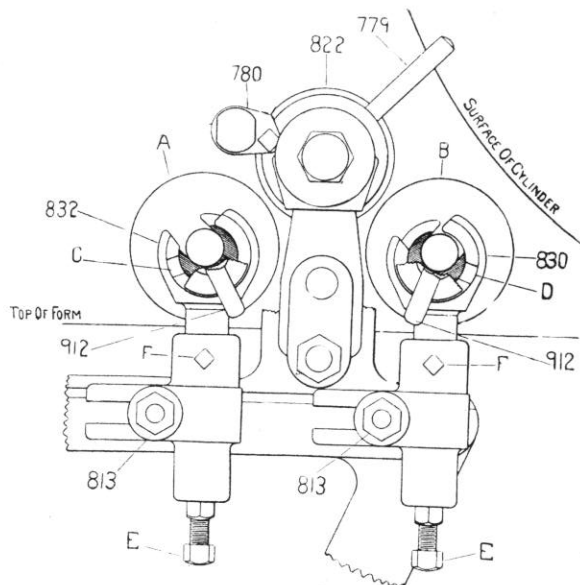

NOS. 35, 41, 43 OPTIMUS. Plate No. 11

contact tends to heat the rollers and melt the composition. This is especially true in the case of new rollers and of summer rollers.

NOTE.—If it is preferred, the ink method of setting the rollers can be used. This method is described for the Nos. 5 to 12, on page 23.

To Set the Diagonal Rollers

No. 35 Optimus

See Book of Parts and Plates No. 3 and 4

Adjust the diagonal roller sockets 0542 up and down to give just sufficient contact between the

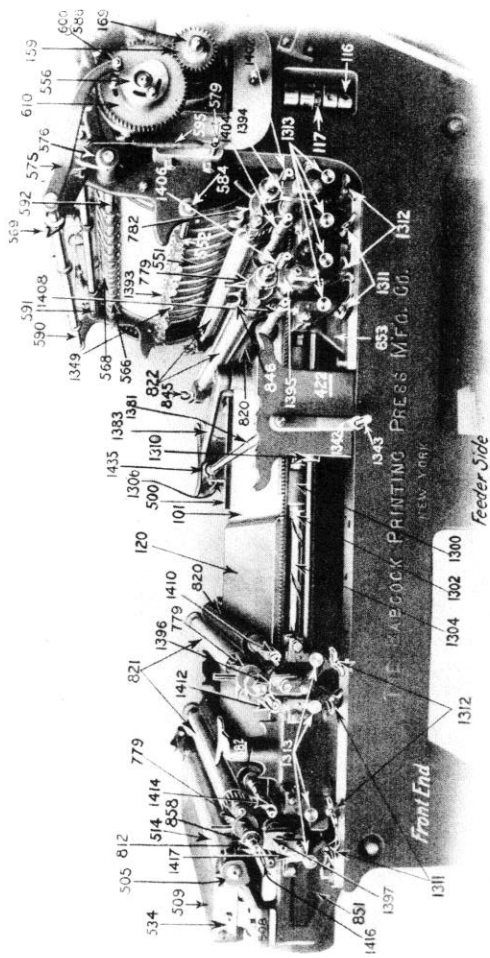

NOS. 5 TO 12 OPTIMUS. Plate No. 13

Throw form rollers out of action by means of thumb cams 1311 and 1312.

Put distributing vibrators in place and set composition rollers lightly to them. Ink up distributors and plate. With the bed on back end, drop the form rollers on to the plate with thumb cams 1311 and 1312 and, without moving press, raise rollers again by means of hand crank 1342. The marks left by the form rollers on the ink plate should be about two and a half picas wide. Adjust up and down until this width is obtained.

Put in form roller vibrators, lock in place by means of button 780, loosen nuts 813 and slide sockets until composition rollers are in contact with vibrators, being sure to get an even bearing entirely across.

Remove distributing vibrators and try composition rollers on ink plate until they bear the same as the form rollers. Put in vibrators and set composition rollers to them lightly, using the method described above.

Be sure all nuts are tight. Run the press slowly and watch rollers closely until assured that there is proper contact between composition and vibrator rollers.

Do not set the composition rollers against the vibrators any harder than is necessary to secure distribution, as too heavy a contact tends to heat the rollers and melt the composition. This is especially true in the case of new rollers or summer rollers.

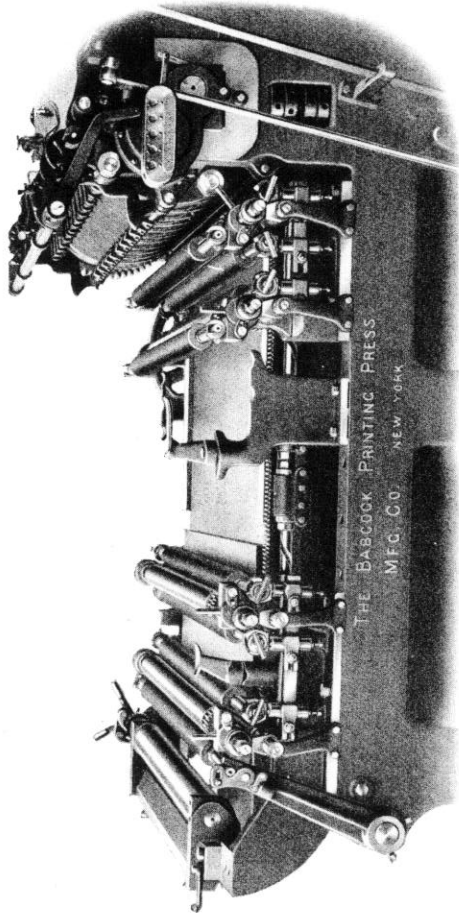

NO. 43 OPTIMUS. Plate No. 14

To Remove a Form Roller

Plates No. 13 and 15

First remove the vibrator roller 822; throw the form roller socket into the "off" position and lift out the roll. Notice that this does not disturb the "set" of the rollers.

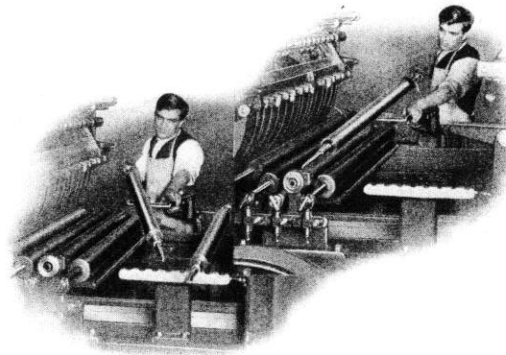

Plate No. 15

Short Forms

When running short forms, keep unused portion of rollers oiled. This prevents them from becoming overheated and keeps the surface in good condition.

To Prevent Flattening

Applies to all presses

Whenever the press is not in use, even for a short time, the rollers should be thrown out of action to prevent flattening. Do not start the press unless certain that all the rollers are either completely in action or out of action. Be sure

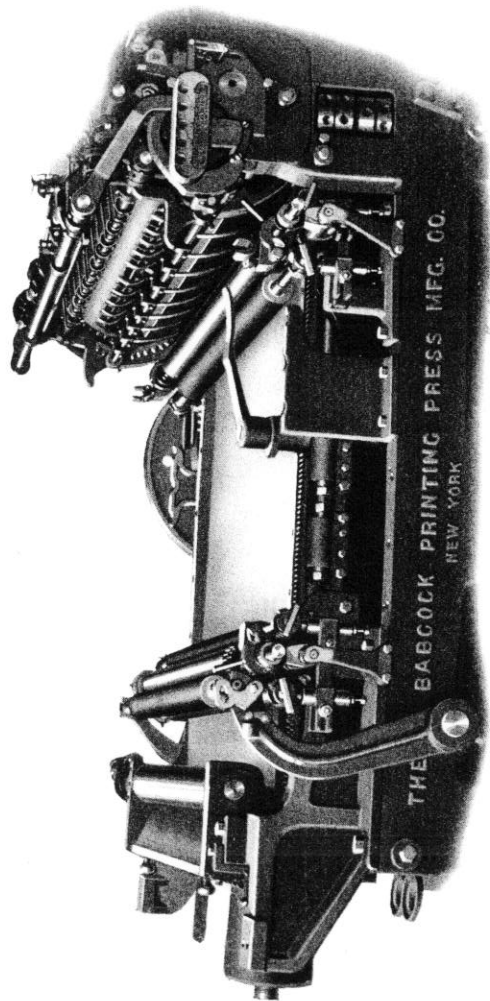

NO. 41 OPTIMUS. Plate No. 16
 NOTE.—The form rollers on No. 35 Optimus are similar to those shown on this plate

the latches on the No. 35, 41 and 43 presses are in the slots, locking them in this position.

All of the composition rollers are of the same dimensions and interchangeable (except on the No. 35 Optimus). The same roller may be used as a form roller, a table roller, a top rider or a duct roller. This original feature makes possible a decided saving, as new rollers may be used on the form, and after serving their time as form rollers, used as distributors until other form rollers take their places, thus requiring new rollers for the form only. Under the ordinary arrangement the entire set would have to be cast new.

To Disconnect the Vibrator Stand

Nos. 5 to 12 Optimus. Plate No. 13

Remove the cam shaft 1381 from the roller rest brackets 421 and 422. Slack off the set screws in the lifting cam levers 1306 and 1310. Take the cap screws out of the foot of the roller rest brackets 421 and 422 and slide the brackets and the lifting cam levers forward until the side shaft is released; then remove the stand in the usual manner.

NOTE.—On the Nos. 5 and 6 Optimus, there is not room enough to slide the brackets forward. In this case, uncouple by sliding the lever along on the shaft.

Spiral Vibrator Shaft

Nos. 41 to 12 Optimus. Plates No. 17 and 18

Repeated tests have shown that, in order to get the best results, the bearings should be adjusted to just take up the end motion, without being tight. They have also shown that the

driving mechanism having been properly adjusted, continues to run nicely, unless it should happen that the shaft became loose enough endwise to allow the thrust collars to drop out of position. However, this will very seldom happen.

To Adjust the Spiral Vibrator Shaft

Place the bed nearly at the back end of its stroke (about 6" off), and moving toward the back end. Plate No. 17 shows it at the front end.

Adjust the back spiral bearing 1305 backward to take up all the end motion between points A and B; then bolt the bearing firmly to the frame. Do not use the set screw in bracket 1305, but instead pull it back as far as possible by hand.

NOTE.—There should always be a clear space between the front bearing 1307 and the spiral gear 1308, as shown on the plate.

After continued use, the brass spiral nuts 1302 are liable to become slightly loose. To remedy this, release the clamp screws C, then turn the nuts (turn top of nut D *towards* the press, and top of nut E *away* from the press) as far as they will go without forcing them, after which tighten the clamp screws C.

Turn the press an entire revolution by hand to see that the bronze spiral nuts are not too tight at any point.

NOTE.—It is important that all parts of the spiral drive be kept well oiled. See oiling instructions on page 85.

It is important that the steel collar section of the ball thrust bearing should fit squarely in the recess provided for it. See Plate No. 18.

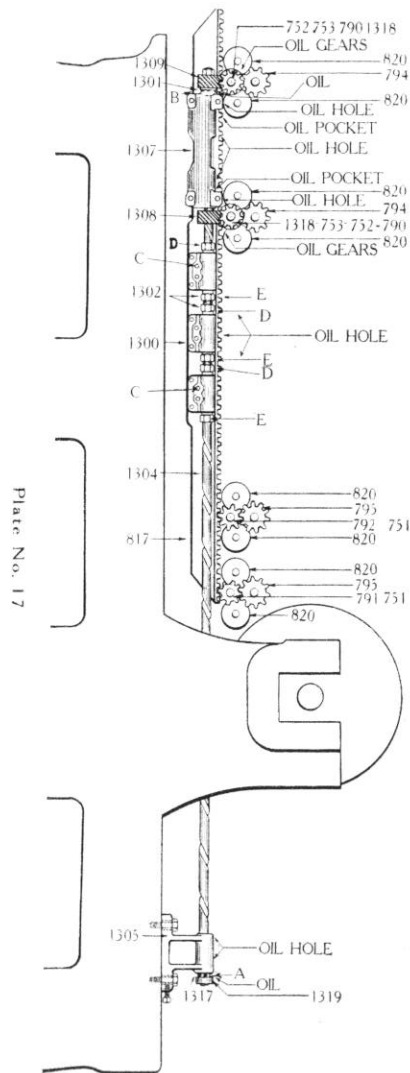

Plate No. 17

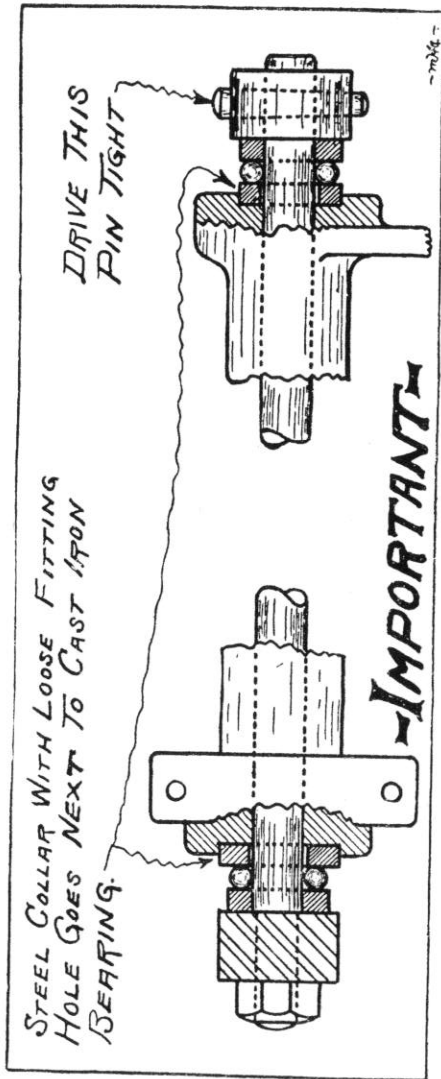

Plate No. 18

Fountain

Plates No. 13 and 19A

To adjust the fountain, first loosen all the screws 511 which hold the steel knife or ductor 510 against the fountain roll 514, Plate No. 13. Begin to adjust the flow of ink at the center of the fountain, tightening the screws gently, working from the center to the ends. Do not tighten the screws at the end of the fountain first, as this may throw a buckle into the middle of the blade.

Tighten the screws carefully, setting up each screw only a little at a time, and going over the screws several times. Watch the roll closely to ascertain whether more or less pressure is required on each screw to maintain an even flow of ink the full length of the roll. It is entirely feasible to cut the ink clean from the fountain roll at any particular point.

In doing this, care must be exercised not to turn the screw up too tight and injure the roll. It should be turned up lightly, until the ink is just scraped off and no more. Adjust the fountain so that the pawls on the slot lever will engage five or six teeth in the ratchet at each throw, or, if the ink is very thick, it may be a tooth or two less. The flow of ink may be regulated more or less by changing the amount of throw without interfering in any way with the adjustment of the screws.

After taking the fountain apart for color wash-up, care should be exercised in replacing the blade or ductor. Loosen all the screws well and set the

fountain back 509, Plates No. 13 and 19A, evenly against the stops in the base, then tighten the bolts.

When the full length of the fountain is not being used, don't choke off the ink at the unused part by tightening the screws to the limit. Plug the unused ends with news print that has been wet and squeezed almost dry, or better still, use a regular fountain divider.

To Grind in a New Ductor

Plate No. 19A

First, see that the fountain roller is not loose in its bearings. If it is, refit the bearings 504 and 505 by filing off the caps and setting them together.

The blade must next be fitted on the ends so that it just touches each end of the fountain, without pinching. All blades are shipped a trifle long, to insure a perfect fit.

Set the blade in place and adjust it to about $3/64$ " (or about 3 points) away from the roll, with all screws slack. Then set up the screws carefully, beginning at the center and working toward each end, until they just hold the blade lightly against the fountain roller. Tighten them carefully, setting up each screw only a little at a time, and going over them several times.

Put a small amount of ink and kerosene mixed to about the consistency of machine oil into the fountain, mixing with it a little powdered carborundum or emery. A tablespoonful or two will be sufficient.

Turn the fountain roller with a slow, uniform motion until the color shows even, entirely across the roller, resetting the screws where necessary to obtain this result. Thirty or forty minutes' rotation is sometimes sufficient, but it may require longer than this.

After the grinding job is finished, the fountain roller should be taken out and the bearings and fountain thoroughly cleansed, to remove the emery.

Fountain Trip

Plate No. 19

When the fountain trip connection 1314 is hooked over stud 1315, in the position shown, it holds the duct roller 819 away from the fountain roller whenever the cylinder is tripped. If, however, the notch 1316 is hooked over the stud, it does not hold the roller off and the press can be inked up with the cylinder tripped.

The appearance of the fountain trip on the No. 41 and 43 Optimus presses is slightly different, but the general operation and the result are the same. The No. 35 Optimus is not equipped with fountain trip.

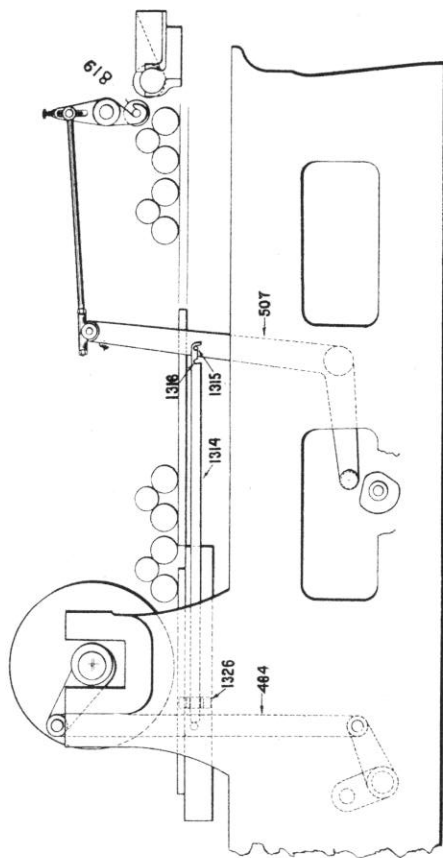

Plate No. 19

To Adjust the Duct Roller

No. 35 Optimus

See book of parts

Put the bed on the front end and adjust the duct cam roll 0479 up or down until the duct roller 0491 just touches the ink slab.

NOTE.—On certain models this roll is adjusted up and down in a slot in the bell crank 0475. On other models the length of the connection is adjusted to bring the cam roll in contact with the cam when the duct roll just touches the slab.

Put the bed on the back end and adjust the stop screw 0477 in the duct bell crank 0475, until the duct roller just touches the fountain roll 0528.

Set up all check nuts tight.

To Adjust the Duct Roller

Nos. 41 and 43 Optimus

Turn the balance wheel until the duct cam roll is on the high side of the cam. Adjust the duct connection up or down in the slotted duct connection lever, by means of the adjusting screw until the duct roller just touches either the fountain roller or the vibrator roller. On certain models the high side of the cam holds the duct roller against the fountain roller and on other models it holds it against the vibrator roller.

Turn the press until the duct cam roll is on the low side of the cam, when the duct roller should just touch either the vibrator roller or the fountain

roller. In case it touches too hard or too light, adjust the length of the connection slightly (about twice as much as seems necessary), then put the press in first position and proceed as before. Set up all nuts tight.

NOTE.—It should not be necessary to adjust the length of the duct connection, except in cases of extreme variation in the diameter of the duct roller.

The position of the duct cam on shaft should never be changed.

Certain old models of the No. 43 are adjusted in the same manner as the Nos. 5 to 12 Optimus.

To Adjust the Duct Roller

Nos. 5 to 12 Optimus

See Book of Parts and Plate No. 19

Turn the balance wheel until the duct cam roll 522 is on the high side of the cam 230. Adjust the duct connection up or down in the slotted duct connection lever 807, by means of the adjusting

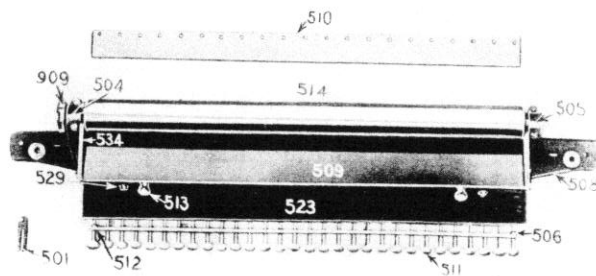

Plate No. 19 A

screw 823 until the duct roller 819 just touches the vibrator roller 821. Put the duct cam roll on the low side of the cam and adjust the stop screw in the gear side roller rest 421 until the duct roller just touches the fountain roll 514. Set up all nuts tight.

It should not be necessary to adjust the length of the duct connections, except in cases of extreme variations in the diameter of the duct roller.

The duct cam 230 is held on the cross shaft by a set screw fitting into a spot in the shaft and located by a register mark on the cam and shaft. The position of this cam on the shaft should never be changed.

Duct Roller Doesn't Bear Evenly Against the Fountain Roller for Its Full Length

The fountain can be squared with the duct roller by loosening the bolt in the feeder side fountain foot 508, Plate No. 19A, and moving that end of the fountain front or back, until the roller bears evenly entirely across.

DELIVERY

Plate No. 20

In assembling the delivery notice that all gears and racks are marked with corresponding numbers when the bed is in the extreme rear position.

For ordinary conditions adjust the top sheet guide wires 1327 up and down collectively, by means of the set screws in the adjusting collar 1328, until they just touch the sheet. If they do not line crosswise of press, they can be adjusted up and down individually by rotating each on its own collar.

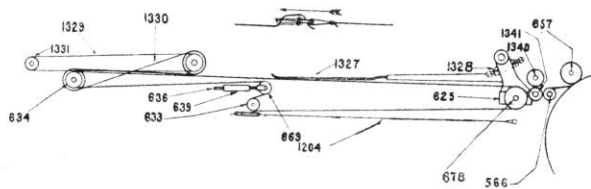

Plate No. 20

The purpose of these top sheet guide wires is to hold the sheet firmly on the tapes while the carriage is stopping. If they are adjusted too high the sheet will slip on the tapes and will not be delivered uniformly at high speed. With proper adjustment the front edge of the sheet will stop on the carriage with the leading edge about $1\frac{1}{2}$ " back from the front edge of the front roll 634.

NOTE.—This applies to the large presses. On the Nos. 35, 41 and 43, they should not touch the sheet, but the hooks at the front end should drop between the tapes when the carriage is at the front end of its stroke and thus stop the sheet.

If the sheet does not stop in the right place, after adjusting the top sheet guides, its position can be varied by adjusting the set screws in the carriage crank 232, Plate No. 2, as follows:

With the carriage in about the center of its travel, slack off both set screws. Now turn the press either forward or backward until the cylinder has moved the amount it is desired to change the position of the sheet on the carriage. Turning the cylinder backward sets the sheet farther back on the carriage and turning forward sets it farther front. Now set up each screw until it just touches the shaft, *then set both of them tight.*

If the carriage shakes and rattles while running, tighten the set screws in carriage crank 232.

NOTE.—On certain models of the Nos. 35, 41 and 43, the carriage crank 0235 (see Book of Parts), is fixed on the shaft and the position of the sheet is controlled by striking the hooked ends of the top sheet guide wires.

Top Strings

Plate No. 20

The top strings 1329 are driven in the same direction as the tapes, by means of the crossed belt 1330. Their purpose is to hold the sheet after it has left the guides 1327.

The front wheels 1331 should be adjusted up and down so the strings will bear well on the front tape roll 634, thus nipping the edge of the sheet between the strings and the roll, carrying it forward positively with the carriage, then rolling it out between the strings and the tapes.

For extremely light paper (like Bible paper), which does not drop fast enough after it leaves the tapes, it is sometimes advantageous to adjust the wheels 1331 considerably lower than shown on Plate No. 20.

Top String Belts

Plate No. 21 shows the correct method of attaching these tape belts, in which the belt is given a half turn, thus twisting and crossing it automatically, and attached so that the tongue

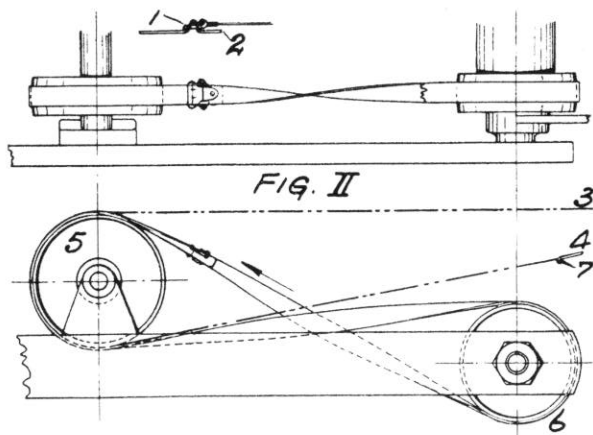

Plate No. 21.

1 of the buckle points in the direction in which the belt is running and with the free end 2 of the tape belt trailing behind on the inside.

To Attach Top String Belts

First pass the tape around the pulley 5 with the free end at 3 and the buckle at 4, observing that the tongue 7 of the buckle hangs down as

shown and that the tape lays perfectly flat and straight.

Now grasp ends 3 and 4 in the right hand and give both together a half turn; next, without twisting either tape, pass 3 around the under side of pulley 6, pass 4 around the top side and buckle the ends together.

Notice

That the same face of the tape comes in contact with each pulley.

That the tongue of the buckle always comes outside away from the pulley and away from the adjoining section at the crossing.

That the free end of the tape always trails behind (when press is running) so that it does not get "mussed up" by contact with the adjoining section when passing it.

NOTE.—The numbers on Plate No. 21 do not correspond with those in the Book of Parts.

Delivery Tapes

Plates No. 20 and 22

The delivery tapes should be drawn up until the spring which acts against the tightener wheel is about three-quarters compressed. After the press has been run for a few days it is usually necessary to shorten the tapes again. The extra length of tape should be cut off until the loose end is not more than $1\frac{1}{4}$ " long where it sticks through and under the buckle, as shown in the cut.

Cut the tape off diagonally to keep it from ravelling.

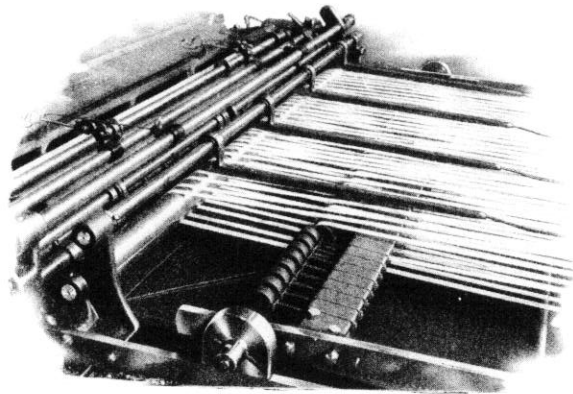

Plate No. 22

After tightening the second time, the tapes seldom need further attention for a long time, as the springs are expected to keep the proper tension on the tapes continuously.

The wooden tape tightener wheels are treated with oil and are not expected to need frequent oiling. But a few drops of oil on the wheels, and also on the springs and spindles, may be found desirable from time to time. If the wheels begin to squeak, it is a sure indication that oil is needed.

If the tapes are drawn tight enough to fully compress the tightener spring, it may create an overload on the tape rolls, causing them to bend and heat. It is well to keep all the tape roll bearings thoroughly oiled.

On some of the presses the tapes are adjustable crosswise of the press by sliding the yoke which carries the tape tightener wheel and spindle 669

and 636 on its support bar 639. On others the wheel spindle is fixed in the support bar and on these presses the tapes are close enough together so it is expected a complete and perfect support will be given to the printed sheet, but at times the form is so located that the edge of a sheet may come exactly against the edge of a tape in such a way that in the process of running off the carriage the corner of the sheet may be caught and run under the tape. It is usually easier simply to remove the tape than to adjust the form on the press, but after the job is finished the tape should be replaced. Always carry a full set of tapes.

If the tapes run off the wheels or break out at the buckles, it indicates that the tongues of the buckles are not inserted central in the tape, or that the buckles are not put on square with the tape.

Sheet Buckles on Delivery

The most common causes of the sheet buckling, or crumpling up on the delivery are:

First The sheet strikes the edge of the tape fastener if it is not properly rounded down.

Second Tapes put on with the buckles heading in the wrong direction. See the arrow on Plate No. 20.

Third Tapes too slack, so that they do not move properly with the carriage.

Fourth Carriage timed incorrectly. See first section of paragraph on delivery.

Sheets Go Backward or Stand Still on Delivery

This may be caused by the roller clutches 1579 and 1589 failing to hold so that the tape rolls 634 and 678 turn backwards when they should stand still. A dose of kerosene oil, followed by machine oil, may remedy this, or they may require new springs and rolls.

Sheet Surges Ahead on Delivery

This is generally caused by slack tapes or not enough of them. Always carry a full set of tapes.

Delivery Fingers

Plate No. 23

Turn the cylinder until its impression surface is under the points of delivery fingers 568 and on its delivering revolution. It will then be slightly

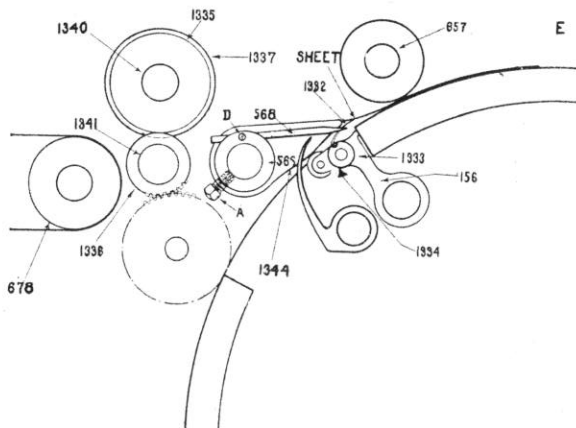

Plate No. 23

ahead of the position shown on Plate No. 23. Observe that the clamp screw D, which holds the delivery finger into the collar 566, fits into its notch in the finger and is set up tight.

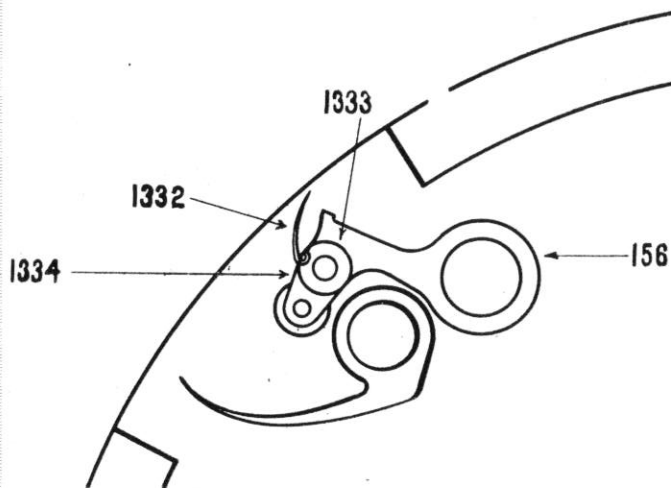

Plate No. 24

Loosen the set screw A, in the delivery finger collar 566 and place a piece of two-point rule, or any other substance about 1/32" thick, on the dressed surface of the cylinder. Press the point of the delivery finger on to this and tighten the set screw A.

Test to see that the point has not changed.

Sheet Lifters

Plates No. 24 and 25

Adjust the sheet lifters 1332 so that each will have a light, equal bearing on the cylinder.

To do this, first turn the press to delivering position and mark the location of the delivery fingers on the tympan, crosswise of the cylinder. Now back the cylinder until the set screws on the sheet lifter collars 1333 can be easily reached. Loosen the set screws in the sheet lifter collars 1333 and insert about the thickness of one point rule between the sheet lifter crank 1334 and its stop pin.

Begin in the center and set each lifter to just touch the tympan, pressing the finger lightly on its point while set screw is being set up. Do not force it against the cylinder by pressing on the center.

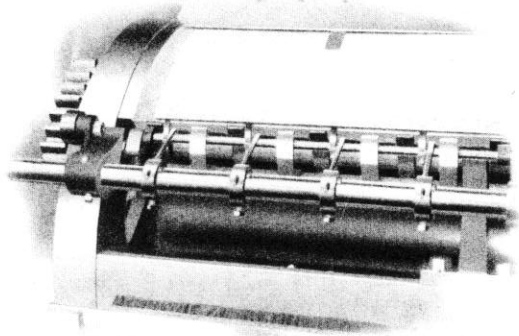

Plate No. 25

The sheet lifters 1332 should be set fairly close to the delivery fingers and to clear the grippers. Thus the sheet is lifted close to the point of the delivery finger, giving ample room for the sheet to slide over the finger. See Plate No. 25.

Sometimes it is well to sink the points of the sheet lifters into the tympan so the top is flush with draw sheet. This can readily be done by cutting a little square out of the tympan, to the proper depth, and directly under each lifter.

When closing the tympan clamps, hold the sheet lifters open by pressing on the little lever at the feeder end of the shaft. This prevents bending the points by striking on the impression edge of the cylinder. On some presses the sheet lifters can be tipped over entirely out of the way when dressing the cylinder. This should be done before opening the tympan clamps 156, care being taken to tip them back into position after closing the tympan clamps; otherwise they may be damaged.

CUTTER ADJUSTMENT

Geared Type

Plates No. 20 and 23

Adjust the rubber-faced top cutter wheels 1335 to run in the margins and resting on the bottom wheels 1336.

Set the cutter blade 1337 to clear the edge of its bottom wheel about a thickness of paper, and a plain wheel; that is, a wheel without a blade, as close to it as possible. Thus each half of a cut sheet will be driven positively by a pair of wheels at each edge.

The hold-down clamps at each end of the top cutter shaft 1340 can be adjusted (by means of the nuts at the top) to hold the wheels at any desired tension and this tension is not "upset" by releasing the hold-downs whenever it is desired to remove the shaft.

The edges of the bottom cutter wheels 1336 are ground perfectly square. Should it be necessary to re-sharpen them, it should be done by grinding the edge of the wheel from the outside circumference square down to the hole. Never grind across the top as this would change the diameter.

Never try to cut with a dull blade. Protect the edge of the blade when not in use by wrapping it in paper. Certain models of cutters are fitted with square edge blades. These will retain their edge longer than the bevelled blade, as the edge is not so easily damaged.

On some presses the bottom cutter shaft 1341 can be taken out without removing the tapes, by removing the back bolt in each bearing 625 (wood roll bearing gear side) and 626 (wood roll bearing feeder side) and letting it swing down around the other bolt until the shaft is easily withdrawn. On other presses this shaft can be drawn straight out on the feeder side by simply removing the gear, which is held in place with set screws.

Cutter Adjustment—Arm Type

Plate No. 26

When attaching the cylinder bands, place the band with the hook 550, to which the cutter

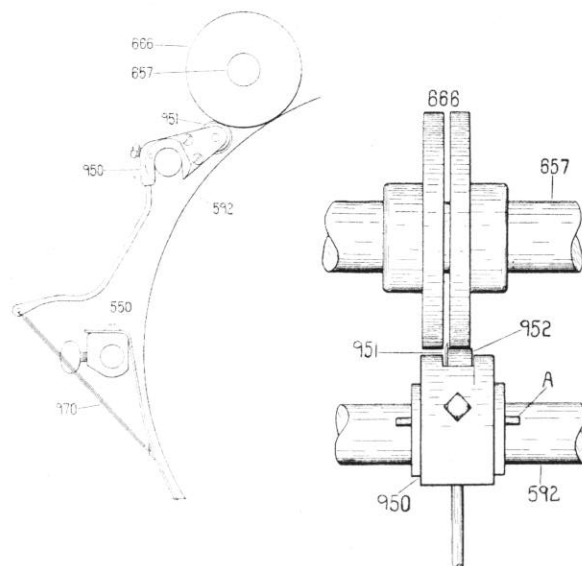

Plate No. 26

spring 970 is to be attached, in the middle. Place the cutter arm 950 on the shaft 592, with the pin "A" fitting between two delivery finger collars 566. Be careful that the pin does not bind between the collars in such a manner that the cutter 950 will not set squarely on the shaft and thus rock easily.

Hook the spring onto the cylinder band 550 and place one of the knurled-faced friction wheels 666 in contact with fibre 952, leaving a space of about the thickness of one sheet of paper between the edge of the friction wheel 666 and the flat side of cutter blade 951.

Set the other friction wheel 666, leaving a space $1/32''$ between it and the bevelled side of the blade 951.

Be sure that neither of the friction wheels run over a gripper. The position of the cutter arm 950 may be changed by releasing the set screw which secures the pin "A."

This set screw must always be set tight when cutter is in use.

If the cutter is set exactly as directed it will give absolute satisfaction; but if the mistake is made of running the blade 951 in contact with the friction wheel 666, the results will be far from satisfactory.

The cutter spring 970 must be kept at a tension sufficient for friction wheel 666, to drive fibre 952. Care should be exercised in removing the cutter to first unhook the spring and avoid stretching it unduly.

In handling friction wheels and cutter, remember they have ground cutting edges which are easily ruined by roughing or nicking. They should be wrapped in paper when not in use.

Keep the cutter bearings clean and well oiled.

Keep the cutter blade sharp.

Keep the friction wheel sharp.

Be sure the wheel turns absolutely free.

Never try to cut when the co-acting wheels 666 and 952 are worn smooth, but replace them with new as soon as they get in this condition.

Delivery Wheels

Plate No. 26

Delivery wheels 666 and 667 should be set to run in the margins. They must not interfere with the grippers.

TO ADJUST THE CYLINDER

Plates No. 8, 9 and 27

First, remove the bearers from the bed, and throw off the trip so as to allow the drop hook 237 to revolve the rocker shaft 473, Plate No. 2. Turn the press ahead until the cylinder is drawn down into position to take the impression, and until the gripper edge of the impression surface of the cylinder

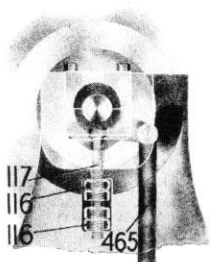

Plate No. 27

has passed beneath the center line of the cylinder shaft, so that the headline marked on the bed will be several inches back of a vertical line through the center of the cylinder; that is, toward the feedboard end of the press, and the star gear 234 will be on top of star gear rack 240, as shown on Plate No. 9. With a pin wrench, adjust the impression screw 117, Plate No. 27, by turning the impression nuts 116 until the bearers on the cylinder are just type-high above the bed. This

can be determined by a large type, passing it forth and back on top of the bed and under the bearers on the cylinder, seeing that it just touches the cylinder firmly.

NOTE.—On the Automatic Piling Cutter and Creaser the bed bearers are not type high, therefore a bed bearer should be used instead of a type for setting the cylinder.

Before setting the check nuts, turn the top and bottom nuts just the width of the pin hole in the right direction to lower the cylinder still farther. This will set the cylinder a trifle below type-height, and is about right for normal conditions.

When this is done, turn up the check nuts hard against the adjusting nuts.

The impression cylinder 157, Plate No. 8, is adjusted very closely at the factory, but usually requires readjusting after the press is erected. The cylinder on a new press should be reset after two or three months' use. Then it should not be changed again unless necessary for some unusual reason.

NOTE.—“Just the width of the pin hole” is a good average amount to lower the cylinder below type height, but it is sometimes advisable to vary this slightly. For instance, a small press doesn't require as much as a large press, and again, some kinds of work require more than others. A half-inch measured on the surface of the nut is often enough for the pony presses, while the 63" press may, at times, require as much as three-quarters of an inch, measured on this surface. See adjustment of intermediate cylinder gear.

To Trip the Cylinder

Plate No. 2

Revolve the rocker shaft 473 so that the lifting connections are forced upward, raising the cylinder in the eccentric boxes. Then raise the drop hook with the foot treadle 407 and 1385, allowing the latches to hold the drop hook and the treadle in this position. The cylinder is now tripped.

If the cylinder bumps down on the form, it indicates that the latch 467 does not hold properly in its notch in the latch bracket 458. The corners may be worn round so that it slides over. In this case, file the corners square and bring the bracket out to the latch by interlaying between the foot of the bracket and the girt.

Or the latch may fit too tight in its notch. In this case file the notch slightly. Again, it may be caused by tripping too late so that the latch does not have time enough to drop into its notch.

To Change the Position of Grippers Relative to Bed

Plate No. 1

Trip the cylinder and mark the teeth of the cylinder and intermediate cylinder gears. Remove the cap screw and washer from the hub of the intermediate cylinder gear 340 and draw the intermediate cylinder gear 340 away from the

press until it is entirely out of mesh with the cylinder gear 158, but still in mesh with the pinion on the main driving shaft.

Turn the press by hand at the balance wheel until the marked tooth on the intermediate gear has passed by the marked tooth on the cylinder gear the required amount, stopping so that the teeth in the intermediate gear come opposite the spaces in the cylinder gear, then slip them into position and replace the washer and bolt.

Turning the balance wheel in the direction it goes when the press is running moves the position of the gripper line towards the front of the press. Turning it in the opposite direction moves it towards the back of the press.

To Adjust the Intermediate Gear Up and Down

Plate No. 1

Slacken the nut on the inside of the frame which holds the intermediate gear stud. Then move the gear up or down by means of the set screws on the outside of the frame, which are provided for this purpose. Be sure and screw the nut up tight on the inside of the frame before leaving it.

Whenever the cylinder is adjusted up or down by means of the impression nuts 116, Plate No. 27, a similar adjustment should be made to the intermediate gear 340, so as to keep the point of

contact between the cylinder gear 158, Plate No. 1, and the intermediate gear exactly correct.

Whenever, for any reason, the intermediate gear is removed, care must be taken that the relative position of the bed and cylinder does not become changed. Mark the teeth so the same teeth will mesh when the intermediate gear is replaced.

The intermediate gear and cylinder gear should run together so that there will be no looseness in the teeth between the gears, when the cylinder 157, Plate No. 8, is down and in position for printing. On the other hand the gears must not be set so close that the teeth will cramp or bind, thereby causing undue strain, which would probably break out the teeth. To test this, draw the intermediate gear forth and back by hand on the stud upon which it turns. If it cannot be drawn out and pushed in, it is an indication that the gears are set together too tight.

To Adjust the Register Rack

Plate No. 8

Release the cylinder trip and turn the press ahead until the register rack 915 is in mesh with the segment and central in the segment. Slack off the bolts which hold the rack to the bed 101 and turn the press ahead for one complete cycle until rack and segment are again in mesh and central. Tighten the bolts just enough so you

cannot move the rack with your hand, but can move it by tapping lightly with a hammer. You may have to determine this first by experiment.

Start the press slowly and gradually increase the speed until it is at about half speed, stop the press and tighten the bolts a trifle more, then bring the press up to full speed, when you will stop it and set the bolts up tight.

NOTE.—Be sure that there is no looseness between the intermediate gear and the cylinder gear before attempting to set the register rack. (See instructions for adjusting on page 57.)

Grippers

Plates No. 25 and 28

Adjust the grippers 160 so that each will have an equal bearing on the cylinder and hold the sheet firmly. To do this, first mark the position of each gripper on the tympan, then loosen gripper screws and try each one to see that they are all loose. Insert a piece of one-point rule between the gripper crank 927 and its stop at the feeder end of cylinder. Start with the middle gripper and work each way, setting each one by pressing its point firmly on to the tympan and tightening its set screw. Do not press the gripper in the center, as it tends to spring the gripper and makes it difficult to set them all evenly.

Test each gripper separately with a piece of the stock to be run, and see that they all have the same pressure on the tympan.

Another method used by some pressmen is to first set the gripper nearest the feeder side of the press, then the third from the feeder side, then the fifth, and so on across the press.

Then, beginning at the gear side, set the remaining grippers, finishing with the second from the feeder side.

In case the grippers are too smooth to hold, it is sometimes an advantage to glue a piece of emery cloth on the packing of the cylinder where the grippers strike. Have this emery cloth folded over the impression edge of the cylinder to make it hold better.

If emery cloth is used in this way, it is well to glue it to the sheet below the top sheet, and cut

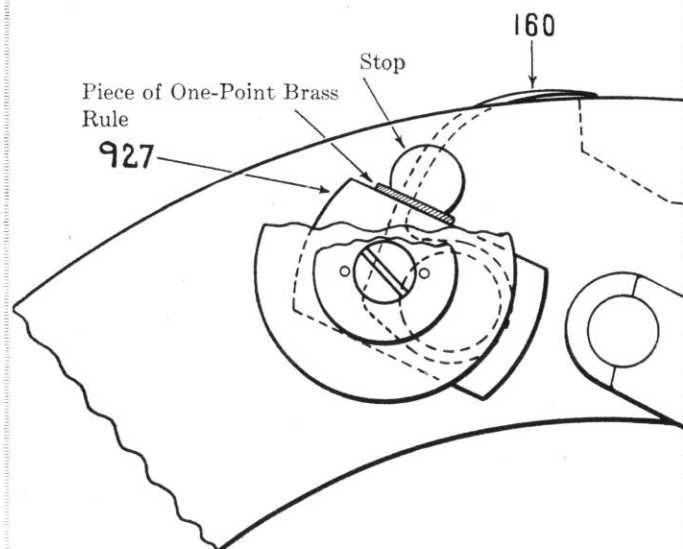

Plate No. 28

the top sheet to correspond with grippers, thus bringing the emery cloth down to level of tympan. Sometimes scoring the smooth part of the gripper with a knife point will produce the desired results. It is a good idea to go over the grippers occasionally to see that they are not flattened, that the points are in line and that they have the right curvature.

If a gripper has been smashed, or if its original curvature has been disturbed in any way, it should either be brought back to exactly its original shape, or else thrown out of action. An imperfect gripper may disturb the set of the sheet and be the cause of faulty register.

The grippers may be turned over and thrown entirely out of action. Nothing is broken if the press is started with the grippers in this position.

Register Brush

With the cylinder *down* on the impression, loosen the brush brackets and place three strips of stock about 2" x 8" and slightly thicker than the stock to be run between the brush and the cylinder. Have one on each end and one in the middle. Tighten the bolts and try the strips. Adjust, if necessary, by loosening the bolts and moving the set screws up or down as required.

It is well to have the center of the brush just a trifle tighter than the ends, for if the ends are tight, and the center loose, wrinkles and bad register are sure to result. Optimus brushes can be bent slightly in the middle to give just the right amount of extra squeeze.

To Adjust for Register

Put a clean top sheet on the cylinder. Take eight or ten impressions directly on this sheet and see that the cylinder and bed run together correctly. If the cylinder and bed do not register, the trouble is probably in the adjustment of the register rack (see adjustment of register rack), or it may be caused by too much or too little air spring, worn yoke blocks, forms improperly locked up, chase improperly locked on the bed or even by erratic power, causing sudden variations in the speed of the press.

After proving that the cylinder and bed run together correctly, stop the press with the grippers just closed. Be sure that the cylinder is packed correctly, then adjust the feed board. To do this, lay a straight-edge on the feed board extending over the cylinder, then raise or lower the feed board until the straight-edge just touches on the edge of the cylinder.

Set the tongues so that they clear the cylinder by about the thickness of one sheet of paper more than the stock to be run. The end of the tongues must be curved to the same shape as the cylinder so that the sheet will lay perfectly straight and flat.

The edge of the feed board must be straight; that is, parallel with the top of the cylinder, so the sheet will be perfectly flat, both lengthwise and crosswise the feed board.

On presses where the feed board is fitted with a steel edge, this edge must be straight. In case the feed board sags, paper or cardboard must be

inserted under the iron braces on the under side of the board to bring it up straight.

Modern presses are fitted with an adjusting screw in the center of the board acting against the iron brace. Turning the screw down raises the center of the board.

See that hinges to feed board are always well screwed on and that there is no play of any sort in the board. A feeder may stand for a few minutes away from the board, and then for a while may lean against it or on it. If movable in any degree, the side guide particularly will be affected and the tongues may not act properly under the feed guides.

Set the grippers carefully (see page 59), first ascertaining that the gripper shaft moves perfectly free with no lost motion either endwise or radially, and that the gripper springs are fairly tight.

Set the feed guides 961 to 968 so they will lift just in time to clear the sheet when it is taken by the grippers, and no more. The feed guides must remain at rest until the latest possible instant. See that the faces of the feed guides against which the sheet strikes are square, so that the sheet will get a straight bearing across the face of the guides. Also, that the faces of the guides are smooth, and the corners not battered in any way that will tend to lift the sheet when the feed guides lift.

Constant feeding may wear a groove in the front of the guides, both drop and side. See that these are kept smooth and true by rubbing down with oil stone or emery cloth.

Set the guides well out toward the corner of the sheet, as this keeps the corners from turning up. Do not allow the feed guides to bear on the tongues more than just enough to get a good contact, as too much weight from the guides tends to bend the tongues, in which case, when the guides lift, the tongues will lift a trifle and possibly disturb the register.

For multi-color work, always set the guides to the same position on the sheet each time the sheet is run through.

Adjust the curved guards on the face of the feed guides so the edge of the sheet will be held close to the feed tongues.

A gripper hold of one-quarter or three-eighths of an inch is usually sufficient. A smaller gripper hold than this may often be desired.

At times it may seem necessary to push the sheet a long way under the grippers. Do not do this. Move the form on the bed. If the sheet is too far forward the grippers may strike it and move it from the guides.

Adjust the drop finger cam 556, Plate No. 13, so that the drop finger wires 959 will drop on to the sheet just before the feed guides lift. The weight of the wires only should rest on the sheet. See that the drop finger wires remain down on sheet until grippers have closed and cylinder moved ahead about two inches.

The "lift" of paper should be kept above and away from the side guide, otherwise the register will vary, due to the sheet not lying flat across the feed board.

In feeding close register work it is good policy to keep the "lift" clear of the sheet being fed; that is, have the lift on the rear of the feed board back far enough so that the sheet being fed will be entirely clear of it.

Atmospheric conditions affect paper. Damp weather enlarges the sheet and dry weather contracts it. A thunder storm may cause loss of register on next color, and waste of such stock as may be printed during the storm. Register may be lost over night because the weather has changed.

All stock printed and unprinted should be carefully protected from humid air. It will even then be found that a few of the top sheets on a pile will not register.

Stock in racks or trays should be protected at the bottom as well as the top.

Papers should always be piled evenly and squarely to guard against atmospheric changes. Roughly piled stock is more exposed to the air.

When paper that is not thoroughly dried is brought into a warm press room, the edges will sometimes shrink, leaving the center of the paper "buckled" or full.

Fine register cannot be had on such paper; neither should paper be brought in from the outside cold and immediately printed. Nor can close register be expected when the paper is charged with electricity. There is now, however, a positive cure for this old-time evil of electricity in the paper, of which printers can avail themselves if they will.

Improper use of gas heaters on the delivery may ruin a close register job.

The cylinder bands 550, Plate No. 26, should be set with care, so as to smooth out the sheet perfectly flat and hold it snug against the impression of the cylinder.

Run the press ahead until the grippers are in line with bands, loosen the bands and set them between the grippers. Run the press ahead until the cylinder is down and on the impression about half way. Now insert a sheet of stock slightly thicker than that about to be run between the cylinder and the bands and set the bands to just touch. This method will hold the sheet firmly and still not mark the sheets or rub the following colors.

Set the register brush as described on page 60.

Certain grades of paper can be smoothed out better by putting a piece of card board, or a piece of heavy top sheet between the bands and the cylinder.

Have the card board run the whole length of the cylinder and lay against the impression of the cylinder evenly. This smooths out the air from under the sheet, and also smooths out the wrinkles. In some cases this is a decided advantage.

For close register it is sometimes necessary to keep the sheet in contact with the tympan all the time. This can be done by attaching one end of a tape to the band rod, passing it in a margin under the cylinder and through a staple driven in the under side and well at the back end of the feed-board. To the end of the tape, attach a weight

large enough to hold the tape close to the cylinder. This enables the tape to follow the rise and fall of cylinder, and if it should break, the weight will cause it to fall outside the press.

When the press is once adjusted so it will register properly, it will retain this adjustment. If a press will register one day, it will register the next.

It is not uncommon for pressmen to say that the press registered yesterday and will not register to-day. Such trouble is not in the press, but should be looked for in the paper or make-ready. Each form is different and needs different treatment. The movements of the press are arbitrary.

A form for close register work should not be locked or spaced with wood furniture, beyond a nonpareil reglet or such matter. Every change in temperature affects wood, either shrinking or swelling it. Some forms give trouble because spaces and quads, leads and so forth, work up. Look for a cut that is warped or improperly underlaid. Such a cut will rock up and down as it passes under the impression. This action lifts the surrounding matter, which the cylinder forces down. A "pumping" is thus established, during which quads and so forth are forced to the surface, become inked and mar the work. Correcting the cut until it lies flat upon the bed is usually the remedy.

Working up of the forms may also occur when the press is out of level, or when the wheel tracks are improperly set. Even setting the cylinder too hard on the bearers may cause it.

An underlay placed on the bottom of a cut is almost sure to cause trouble. Put it between the plate and block. If a cut that rocks is not over type high, it can sometimes be corrected by pasting narrow strips of paper on the corners that are low.

See that the corners are square, the sides and ends perpendicular and that it offers a true lock-up. Sometimes a poor chase is the source of this evil.

Upon receiving a form the first duty of the pressman is to bring the cuts up to type-height by interlaying those which are low and dressing off those which are high, so that the surface of the form will be as level and as even as possible.

When the form is even and smooth, it is possible for the pressman to obtain an even and smooth cylinder, and both are necessary if good register is required.

The pressman should never forget he is working on a machine whose every motion is calculated to a nicety, so accurate that a thickness of paper makes a marked difference in adjustment, and this same difference may change the relative motions of the bed and cylinder, or change the forms and tympan surfaces, which must travel together with absolute precision.

Always run a register job at constant speed. You can not expect your press to register at varying speeds.

Make-Ready

With the bearers of correct height, the cylinder should be set upon them firmly enough to hold the cylinder there when the form is properly made-ready. The tympan must not be more than

one sheet higher than the bearers on the cylinder.

The surface of the bearers on the cylinder is calculated to travel at exactly the speed of the bed.

If the attempt is made to make-ready a form without paying attention to the heights of the cuts, it will be found that certain spots on the tympan will be higher and other spots will be lower than the surface of the bearers on the cylinder.

The low cuts on the form may slur, the high cuts will give a larger impression than they actually measure, because with these cuts it is impossible for the printing surfaces to run together with exactness, and one creeps upon the other. This has a tendency to swing the sheets, as at the surface of the high spot the tympan and form are not running in unison, and the sheet must give.

Tapes and brushes may be put on; the bands set so tightly as to mark the sheet; the grippers set perfectly; guides changed; and all else done to overcome the fault, but the sheet will continue to swing, because one portion of it travels faster than the other.

Cutting out the tympan where the impression is too great, or overlaying with heavy paper where it is too light, will not only make register impossible, but will make it difficult to keep the tympan on the cylinder, as it twists under the strain of impression. At the uneven portions there is a drag or push instead of the firm, steady and direct touch that would ensue if the surface of the tympan and form traveled together as they should.

If the tympan pulls out from the tympan clamps, it generally indicates that the press is out of level or that the cylinder is not properly down on the bearers so that the tympan is more than bearer high, or it may be that the form is under type high.

If there is a border or rule around the job or cut, or a page with an open center, this unevenness in make-ready not only makes register impossible, but produces a disfiguring wrinkle on the edge of the sheet farthest from the grippers. The remedy is proper make-ready. This defect is very noticeable on map and similar work.

To prevent the wrinkle or buckle, see that the plates are absolutely type high and so nearly uniform that a thin over-lay is all that is necessary.

Most wrinkles on border forms can be eliminated by adding triangular strips of card sufficiently large and high enough to take up the amount of wave or buckle in the sheet. These strips are to be glued in the margins at back and sides of sheet and on gripper edge if necessary. Care should be taken that the strips remain in place throughout the run, as poor register will result if any strips are lost.

It is assumed that the pressman has properly dressed the cylinder; that the press board lies firmly and flatly on the metal; that the sheets are the right number, even and smooth; that the draw sheet and tympan are uniformly tight, without buckle or wrinkle, but lying flat and smooth on the cylinder. These conditions must prevail before any attempt is made to make ready.

Chases

Imperfect chases cause loss of register as completely as badly trimmed cuts. A badly sprung chase can, sometimes, be held down by placing a strip of card or lead rule about one pica wide between furniture and chase at bottom. This applies also to springy type matter, cuts, etc.

See that the patent quoins on register work do not lock against the steel of the chase, or against metal furniture. Interpose a bit of cardboard or reglet. For close work a straightaway quoin is best; that is, a quoin with a screw in the center that pushes directly outward. Quoins on the wedge principle have a forward and backward thrust, and it requires great care to lock these twice alike without more or less twist.

If it is necessary to unlock a form, or guides have been moved, put a brad in the side guide end of the form to just show on the end of the printed sheet. Add a brad for each change. This will enable one to keep all changes together throughout a run.

On close register work, always keep a number of old sheets on the feed board, and lay the stock to be printed on these. This will eliminate stretching of sheets due to the cold feed board.

Slur in Printing

Not only does faulty make-ready too often cause loss of register, but it quite as frequently is the source of slur. We enumerate some of the causes of slur.

Loose, springy and poorly underlaid plates.
Over make-ready under plate or on cylinder;
in other words, over packing the cylinder.
Make-ready too high above bearers.
Failure to reduce packing for very thick stock.
Last roller not in contact with vibrator.
Cylinder not hard enough on bearers.
Bands not tight enough to cylinder.
Form locked too tightly with bed clamps,
causing spring.
Form locked with imperfect furniture or
quoins, causing spring.
Feed tongues too high above tympan. This
will sometimes cause sheet to buckle.
Poor justification and make-up.
Badly sprung chases.
Too much paste on overlays, or slovenly
attached overlays to gripper edge of packing, or
carelessly cut and attached underlays.
Loose or buckled tympan sheet, or spongy,
springy packing.
Loose register rack or segment.
Form too large for press, or set too near front
edge of bed, thus printing after bed has commenced
to stop.
Impression rolls not set properly.
Intermediate gear too tight.
Screws above surface of bed bearers.
Insufficient packing on yoke block.
Press out of level.
Bed bearers underlaid.
Cylinder boxes worn loose.
Too much or too little air spring.

Bed bearers too high or badly worn and
uneven.

Knowing the cause, one should easily overcome
the trouble. Examine your own work first, then
the compositor's work, then examine the press.

Orders for Repairs

*When writing about a press in use, or referring
to a press in any way, always specify the shop
number of the machine.*

This number is stamped on the patent plate;
also on the side frame, feeder's side, directly under
the cylinder shaft journal, and on one corner of the
bed, see Plate No. 2.

New parts for repairs should be ordered by the
numbers as shown in the book "Parts of the
Optimus Press." Do not order by numbers
cast or stamped upon parts, but according to the
instructions in that book. There is a separate
book of parts and set of numbers for the Nos. 35,
41 and 43 Optimus, and for the Nos. 5 to 12
Optimus. Confusion of the different styles of
presses and their accompanying books of parts
should be carefully avoided.

*CAUTION.—After making any adjustment, it
is advisable to turn the press by hand through one
impression to make sure that there is no inter-
ference. Such interference is a source of danger of
breakage.*

ADJUSTING THE AUTOMATIC PILING CUTTER AND CREASER

This section only treats of those adjustments which are different from corresponding adjustments on the printing press.

To Raise the Jacket

Plate No. 29

First, raise the feed guides and the cylinder friction wheels. Turn the press ahead until the bed reverses at the front end and continue, if necessary, until the back clamp buttons can be easily reached. Slack off the tension screws in the back clamps (these clamps hold the tail end of the jacket), and tap the clamps lightly to free them. Back the press by hand until the grippers come up and open the full throw. Do not back it more than enough to just open the grippers.

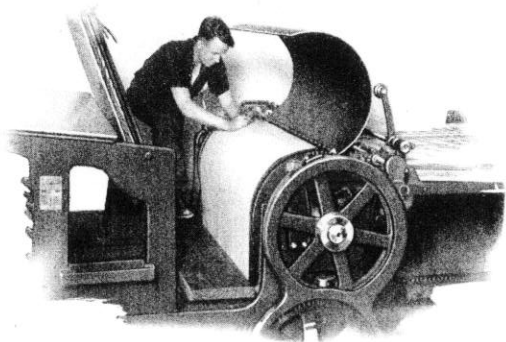

Plate No. 29

Throw the grippers clear out of action by turning back as far as they will go, loosen the tympan clamps by means of pin wrench same as in printing press. Turn the press ahead slightly, if necessary. Don't try to lift the jacket yet, but take hold of the tail end of the jacket, and, without lifting it, push the jacket roundwise the cylinder towards the grippers until it is free from the dowel pins in the gripper edge, then lift straight up.

The jacket will now be in the position shown on Plate No. 29, and resting against the cylinder friction wheels, thus protecting the feed guides from damage by contact with the jacket.

In this position the jacket can readily be lifted directly up and off from the hinge pins, thus removing it entirely from the press if it is desired.

CAUTION.—Never move the press with power while the jacket is released.

To Replace the Jacket

Reverse this process, being careful that the jacket bar is properly seated over its locating pins before setting up back clamps.

In tightening the back clamps, start in the middle, and work out towards each side.

Don't set up end clamps first.

Before closing the grippers, see that the gripper cam roll is under the highest part of the cam. If this is done the grippers cannot close on the fingers.

To Adjust the Jacket Relative to Cylinder Bearers

Place sufficient tympan manila between the jacket bars (the jacket bars are made in two sections, screwed together and have the jacket permanently attached to the top one), and underneath the jacket so that the top surface of the jacket just touches the cutting rule.

The latest models are designed to be run with the surface of the jacket somewhat below the the cylinder bearers, thus compensating for the thickness of the skeleton and sheet, also for the "draw in" due to the creases.

It is impossible to make a machine that will always compensate for these items owing to the varying conditions.

Babcock Automatic Piling Cutters and Creasers are made exactly right for all ordinary conditions and can readily be made right for any extreme variation from ordinary conditions. For instance, if the cut comes short, underlay the bearers and add underneath the jacket. Whenever the bearers are underlaid, the set of the cylinder should be adjusted to correspond.

For an occasional run, under unusual conditions, the die can be either shortened or lengthened to compensate for the difference.

Always set the grippers with the skeleton in position and with a piece of the stock that is to be run underneath them.

The jacket underlay should always extend over the entire surface of the cylinder, regardless of the size of the job.

When new, the bars are to be interlaid until proper cutting height is reached, after which they require very little attention. It is well to carry one thickness of .006" manila more between the jacket bars than there is on the cylinder. Glue the manila between the jacket bars to the lower bar as it will remain there permanently.

Height of Cutting and Creasing Rule

To get the best results, and the easiest make-ready, use .923" cutting rule.

It is impossible to adopt a single height of creasing rule to correspond with the standard height of cutting rule on account of the various thicknesses of stock used in the different types of boxes. Creasing rule, which is from .020 to .030" lower than the cutting rule is commonly used for ordinary thicknesses of folding box stock, but it plainly will not do at all with the thick stock which is used for some classes of boxes.

The height of scoring rule should be sufficient to score about half way through the sheet.

Babcock bearers are made the correct height for above rule. If higher rule is used, the bearers should be underlaid and the height of cylinder adjusted to correspond.

Be sure that the lower jacket bar rests firmly on its seat at the impression edge of the cylinder. It is always best to use new cutting rule at the gripper edge of the die.

Cutter and Creaser Cylinders

generally need to be set a trifle harder on the bearers than printing press cylinders. They are likely to give up a little during the first few months of use. Therefore, it is always well to have them re-set some time during the first year.

Make-Ready

Start with a clean jacket and with the form located in correct position on the bed.

Build up underneath the jacket until the cutting rule just touches it, and no more.

After the cutting rule is made ready, glue a light, soft sheet, not more than .006" thick, to the jacket, pull an impression on this and glue the skeletons on to the impression made on this white sheet.

After the skeletons are glued on firmly, ink all the creasing rules and pull an impression at about the speed you are going to run the job. If the creasing rule appears weak in spots, it is well to build up the skeletons at these points.

Cut the creases, taking care that they are very accurate and not any wider than is necessary to prevent cracking.

After cutting creases it is well to rub down the rough edges left by the knife.

Shoo-Flys

Adjust the length and lift of the shoo-flys to accommodate the job that is being run.

NOTE.—The lift can be adjusted by means of the set screw in the cam lever at the feeder end of the cylinder.

If the points of the center shoo-flys touch the die on the second revolution, set them with two or three sheets of manila under the end fingers. Then slack off the set screw in the cam lever so that with the shoo-flys closed, the set screw clears the stop about $\frac{1}{16}$ ".

CAUTION.—Never leave the shoo-flys up while the press is being turned backwards. Better remove the shaft from the press until you are ready to run.

Delivery Fingers

Be sure that the delivery fingers are set high enough to clear the jacket when the skeleton is on.

Notice

THAT THE TIME OF THE JOGGER can be adjusted to suit various conditions by rotating the jogger cam on its shaft.

THAT THE DRUM SHAFT is provided with automatic stop lever, which prevents the pile table from going too high or too low.

THAT THE DOWNWARD FEED of the table is adjusted with a thumb screw similar to that used on the Extended Delivery. See section on Extended Delivery.

THAT THE LOWERING CLUTCH must be released by slacking off the set screw in its hub before raising the table. See section on Extended Delivery.

THAT THE CYLINDER FRICTION WHEELS are attached to independent arms. They should be set to just touch the sheet and no more. They should never touch the jacket.

THAT THE BUTTONS IN THE BACK CLAMPS are easily adjusted in and out by slacking off the set screws which hold them in place.

THAT THE PLAIN COLLARS on the delivery finger shaft should come opposite the buttons in the back clamps.

Delivery

The delivery should be timed so that the leading edge of the sheet stops about even with the front edge of the front tape roll.

If the sheet does not stop in the right place, after adjusting the cylinder friction wheels and the rubber-tired driving wheels, its position can be varied by adjusting the set screws in the carriage crank 232, Plate No. 2, as described on page 41.

ADJUSTING THE EXTENDED DELIVERY

Delivery

The sheet should be timed on the delivery exactly the same as it is on the regular printing press delivery (see page 40).

To Adjust the Table Supports

The Extended Delivery is ordinarily shipped from the factory with the supporting cables properly located for a full size piling table, but they can be easily changed to accommodate any reasonable size table by the simple expedient of shifting the position of the grooved pulleys.

To Adjust the Length of the Cables

Put the table in its raised position. Slack off the set screws in the winding drum to which the particular cable is attached, and turn the drum shell on its sleeve until the top of the table just clears the bottom of the jogger wing. Then set the set screws up tight.

NOTE.—On certain models the drum cannot be turned on its shaft, or sleeve, in this case it is necessary to pull the cable through the hole in the drum. Then set the set screws up tight.

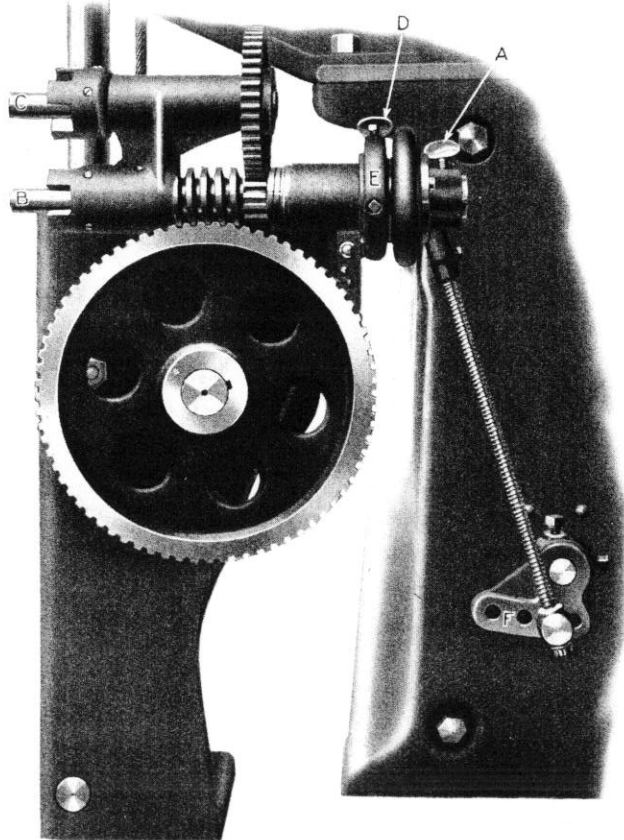

Plate No. 30

Jogger

The front wings do not move back and forth, but have a slight adjustment. An observation of the pile will show whether or not they need adjusting. This is easily done by slacking off the bolt in the supporting bracket at each end of the wing bar.

To adjust the back and side wings, grasp the ends of the wing rod yokes between thumb and forefinger, pinch them together slightly and slide the yoke along on its rod.

To Release the Down Feed

Plate No. 30

Slack off the thumb screw "A" in the clutch hub, located at the extreme right-hand end of the worm shaft "B."

To Start the Down Feed

Plate No. 30

Set up the thumb screw "A" tight.

To Raise the Pile Table

Plate No. 30

Slack off thumb screw "A" and use the hand crank on the end of shaft "B," or shaft "C." This crank can also be used to lower the pile table by hand without releasing the screw "A."

To Adjust the Down Feed

Plate No. 30

Adjust the screw "D," which acts as a stop for the reciprocating lever on the worm shaft.

For extreme variations in the adjustment, rotate the stop collar "E" and use the screw "D" for the fine adjustment.

Notice

THAT THE OUTSIDE FEED LEVER "F" has several holes for attaching the connection. For ordinary thickness of paper use the hole nearest the shaft. For cardboard move it away from the shaft.

NOTE.—On certain models this lever is attached to the side frame of press, as shown in the picture—on other models it is attached to the extended delivery bracket.

THAT ONE REVOLUTION OF THE ADJUSTING SCREW "D" varies the downward feed $1/1000''$. Turning it clockwise decreases the feed, counter clockwise increases it.

THAT THE SCREW "A" IN THE CLUTCH HUB at the extreme right-hand end of the worm shaft must be released before returning the pile table to its up position.

CAUTION.—When erecting, have some one pull the cables while you are unwinding them from the drum, otherwise they will get tangled up.

In action, never unwind the cables after the ends reach the floor. If you wish to run the press after this, throw out the automatic feed by releasing the screw in the clutch hub.

OILING THE PRESS

When erecting the press the oil holes should be carefully observed and thoroughly cleaned out.

A new press needs much more frequent and careful oiling than an old press. Great care must be taken in this matter.

On a new press the bearings are closely fitted. If permitted to run without oiling they become hot, the metal expands and the machine comes to a sudden stop. It is stuck. Often new parts must be obtained and frequently at great expense, all of which can easily be avoided by careful oiling.

Experienced pressmen know which parts of the press need most frequent oiling. The main parts of a new press should be oiled five or six times a day, and if there is any inclination to get warm in any particular part, it should be oiled more frequently.

An easy rule for oiling a printing press, or any other machine, is that every part which moves should be oiled. If the oil hole is not easily discovered, look for it and keep it well cleaned out. It is easy to

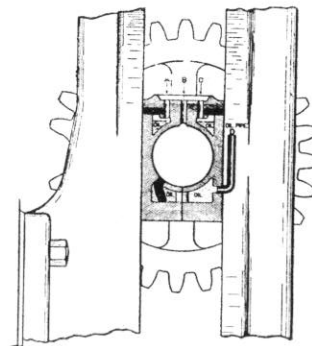
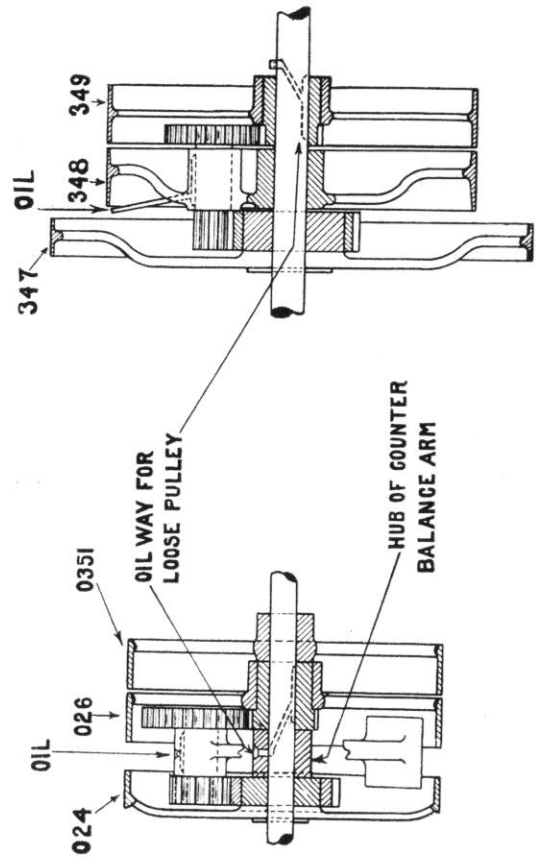

Plate No. 31



Nos. 5-12, Optimus, if fitted with mechanical back up

Plate No. 33

Nos. 35, 41, 43 Optimus, if fitted with mechanical back up

discover whether a part moves or not. If it moves, oil it at its point of contact or bearing. A little extra oil does no harm.

All the tape roll bearings should be oiled liberally. On certain sizes of presses, the oil holes for the front tape roll are through the string shaft bearing. Don't overlook them.

The rolls on the end of the star gear rack, and the roll on the star gear, have no oil holes. These rolls have large motion, endwise, on their studs. Put oil upon both ends of these studs and move the rolls

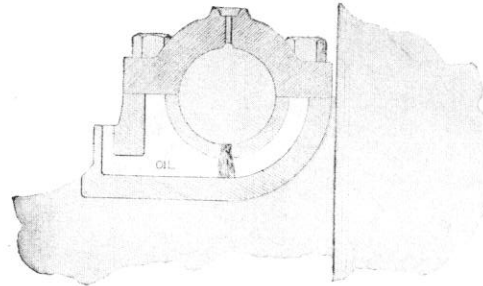

Plate No. 32

forth and back with the fingers, thus oiling the stud and insides of the rolls. Also, oil the inside of the bed reversing shoes at the ends of the star gear rack.

It is important that all parts of the spiral drive be kept well oiled. See Plate No. 17. Oil at A and B twice each day.

Oil the gear teeth wherever found. Oil the tracks under the bed, both the roller tracks and the wheel tracks.

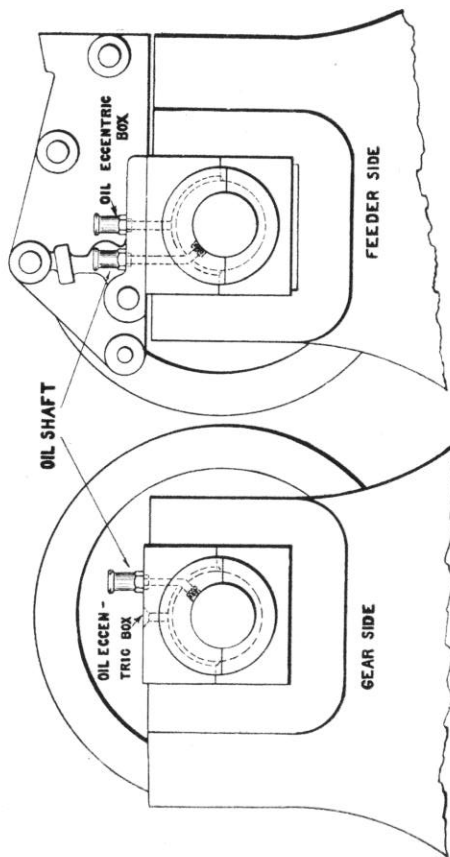

Plate No. 35

It is desirable to use kerosene oil occasionally in the roller tracks. This softens the gum of the machine oil and makes the sliders run easily.

It should be put in at night, the press run a few turns, then allowed to stand over night. In the morning run a few turns, then wipe the kerosene out carefully, after which apply a liberal quantity of good machine oil.

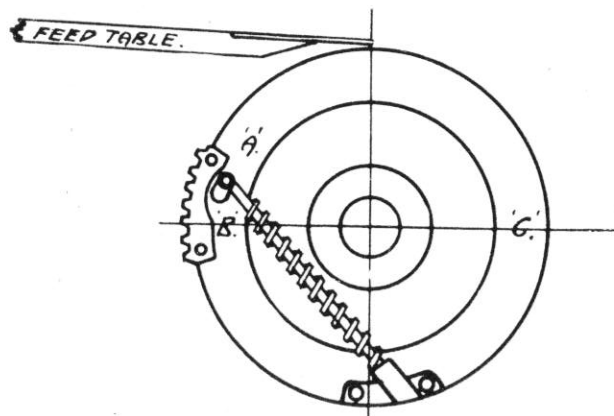

Plate No. 34

Note that the loose pulley 349 and 026, Plate No. 33, is running when the press is idle, and, therefore, needs oiling whether the press is used or not. Plate No. 33 shows the method used in oiling this pulley on presses fitted with mechanical back up.

It is desirable to use kerosene oil occasionally in the loose pulley, following the method described above.

Oiling Cylinder Boxes

Plate No. 35 shows the method of oiling the cylinder boxes. As the oil holes are large and long, they will require considerable oil before it reaches its destination. Do not make the mistake of thinking a few drops sufficient. There is no danger of using too much.

All No. 35, 41 and 43 Optimus presses having a serial number smaller than 7700 should be oiled with the cylinder down.

NOTE.—All No. 41 Optimus presses having a serial number smaller than 7001 should be oiled with the cylinder up.

All No. 35, 41 and 43 Optimus presses having a serial number larger than 7700 should be oiled with the cylinder up.

All No. 5 to 12 Optimus presses should be oiled with the cylinder up.

Method of Oiling Gear End Gripper Spring Rod

Turn the cylinder into about the position shown in relation to horizontal line "BC," Plate No. 34. Oil hole can then be easily reached under register segment at "A."

INDEX

	Page No.
Bands, cylinder to set.....	66
Bearers, on bed.....	18, 19
Belt, top string.....	42
Brush, register.....	61
Chases.....	71
Cutter, geared type.....	50, 51
Cutter, arm type.....	51, 52, 53
Cylinder, to adjust.....	54, 55
Delivery, to adjust.....	40, 41
Fingers, delivery.....	46, 47
Fountain.....	33, 34
Fountain, blade to grind in.....	34, 35
Gear, intermediate cylinder.....	57, 58
Gibs, bed.....	14, 15
Gripper line, adjustment of.....	56, 57
Grippers, to set.....	59, 60
Leveling.....	8, 9
Lifters, sheet.....	47, 48, 49
Make-ready.....	68, 69, 70
Motor runs hot.....	10
Oiling.....	85, 86, 87, 88, 89, 90
Numbering, system used.....	7
Paper, handling of.....	64, 65
Power.....	10
Rack, register.....	58, 59
Register, to adjust for.....	62, 63, 64, 65, 66, 67, 68
Repairs.....	73
Rollers, diagonal.....	21, 23
Rollers, duct.....	37, 38
Rollers, duct, to adjust.....	37, 38, 39
Rollers, to remove.....	27
Rollers, to set.....	20, 21, 22, 23, 24, 25, 26
Shaft, spiral vibrator, to adjust.....	29, 30, 31
Sheet buckles.....	45
Sheet surges ahead.....	46

INDEX—Continued

	<i>Page No.</i>
Slider controller	14
Sliders, to adjust	13, 14
Slur, to adjust for	71, 72, 73
Sockets, roller	19, 23
Springs, air	16, 17, 18
Stand, vibrator to disconnect	29
Strings, top	41, 42
Table, feed to adjust	62
Tapes	43, 44, 45
Terms used	7, 8
Tracks, wheel	11, 12, 13
Trip, cylinder	56
Trip, fountain	35, 36
Wheels, delivery	53
Wrinkles	70
Yoke block packing	15

CUTTER AND CREASER SECTION

Cutter and Creaser	74
Bearers	76, 78
Cutting rule	77
Delivery	80
Fingers, delivery	79
Jacket	74, 75, 76
Make-ready	78
Shoo-flies	79

EXTENDED DELIVERY SECTION

Extended delivery	81
Cables, to adjust length	81
Feed, to adjust	83, 84
Jogger	83
Table supports	81

