

Presswork Unit No. 4

Operation of the Miehle Vertical Printing Press

C. Milnor Cook



Department of Publishing and Printing
Rochester Athenaeum and Mechanics Institute
Rochester, New York

Copyright 1938 by
Rochester Athenaeum and Mechanics Institute
Rochester, New York

INTRODUCTION

This booklet is one of a series of instructional manuals used in the day and evening classes of the Department of Publishing and Printing, Rochester Athenaeum and Mechanics Institute, Rochester, New York.

The purpose of this booklet is to provide a guide to the necessary steps in setting up a Miehle Vertical printing press for any job, as well as to furnish technical data on how this job is done. This manual, with the demonstrations and verbal instructions of the teachers of presswork, should enable the student to set up and print any job which can be run on this type of press.

No attempt is made in this manual to teach the makeready of a job, as this is taken up in a separate manual on "Makeready Practice."

The Department of Publishing and Printing is indebted to the Miehle Printing Press Company for the illustrations appearing in this manual.

R. Randolph Karch
Technical Supervisor

Objectives of the Unit

1. To help the student get a clear-cut picture of all the steps in the operation of a Miehle Vertical Printing Press.
2. To enable the student to practice makeready on the Miehle Vertical Printing Press.
3. To enable the student to become proficient in the operation and adjustments of a Miehle Vertical Printing Press.
4. To help the student get an understanding of the fundamental engineering principles involved.

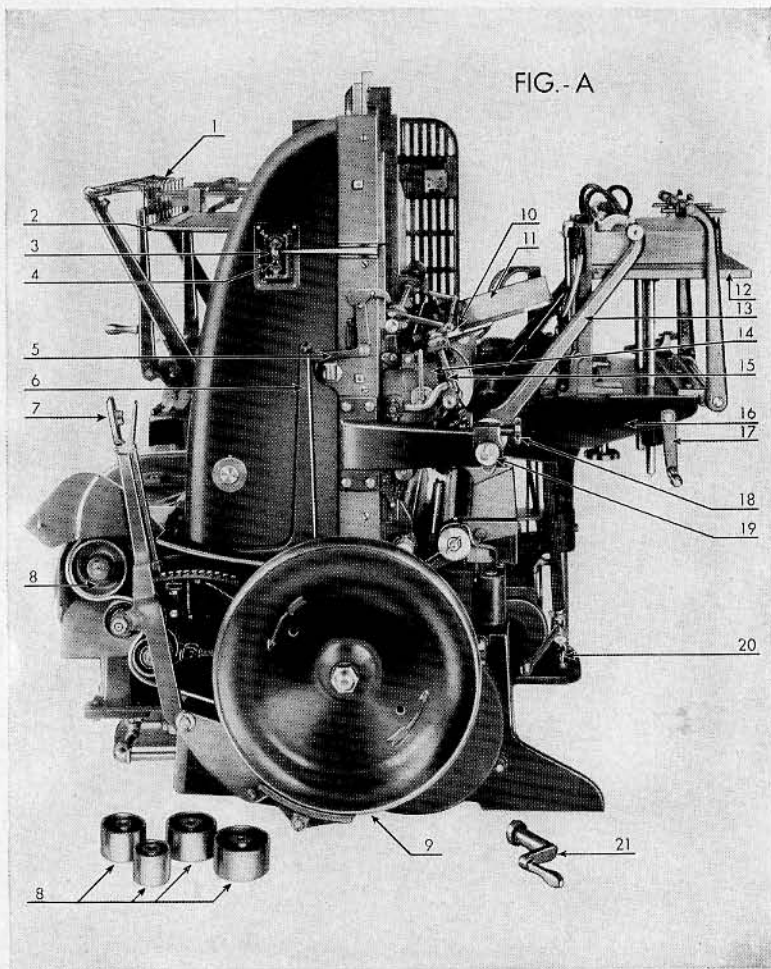

Fig. A. Side View of Miehle Vertical

- | | |
|-------------------------------|-----------------------------------|
| 1. Delivery grippers. | 12. Feeder table. |
| 2. Delivery table. | 13. Feeder arms. |
| 3. Stop button. | 14. Transfer table stops. |
| 4. Starting button. | 15. Transfer table levers. |
| 5. Belt tightener trip latch. | 16. Feeder platform. |
| 6. Belt tightener trip lever. | 17. Feeder table crank. |
| 7. Belt tightener lever. | 18. Feeder lock screw. |
| 8. Driving pulleys. | 19. Feeder control knob. |
| 9. Flywheel. | 20. Blast pet cock and oil drain. |
| 10. Side guide. | 21. Fountain crank. |
| 11. Transfer table. | |

The Miehle Vertical Press

The Miehle Vertical Press will handle sheet sizes from $3\frac{1}{4} \times 5\frac{1}{2}$ inches up to $13\frac{1}{2} \times 20$ inches on stock varying from thin paper to light carton stock.

The printing area is $12\frac{1}{4} \times 19$ inches.

All the tools necessary to operate the press are; a large and a small pin wrench, and a small screw driver.

The speed range is from 2500 to 4500 per hour. (Old models, 2000 to 3600 per hour.) Speed changes are effected by raising a belt guard and slipping on pulleys for speeds of 2500, 3000, 3500, 4000, and 4500 per hour.

NOTE—Figure A shows the side of the press commonly termed "Feeder Side." The opposite is called the "Gear side." These terms will be used in this manual.

To Operate

1. Starting and Stopping

- a. Be sure belt tightener lever is back. In this position belt is slack and brake is on.
- b. Press black starter button to start motor.
- c. Pull belt tightener lever forward, all the way. This also releases the brake.
- d. To stop the press; squeeze the handle and shove all the way back. This also applies the brake.
- e. Stop the motor by pressing the red button.

NOTE—Do not start and stop the press by using the control buttons. Always use the belt tightener lever.

2. Feeding

- a. To start feeding—Push control knob IN on the back stroke of the feeder arms. (When arms are traveling toward the feeder pile).
- b. To stop feeding—Pull control knob OUT on the back stroke of the feeder arms. (If suction is cut off on the forward stroke of the feeder arms, the sheet will fall away from the suction shoes).

3. Oiling

- a. At regular intervals.
- b. Start at the same place each time and continue around press until starting point is reached.

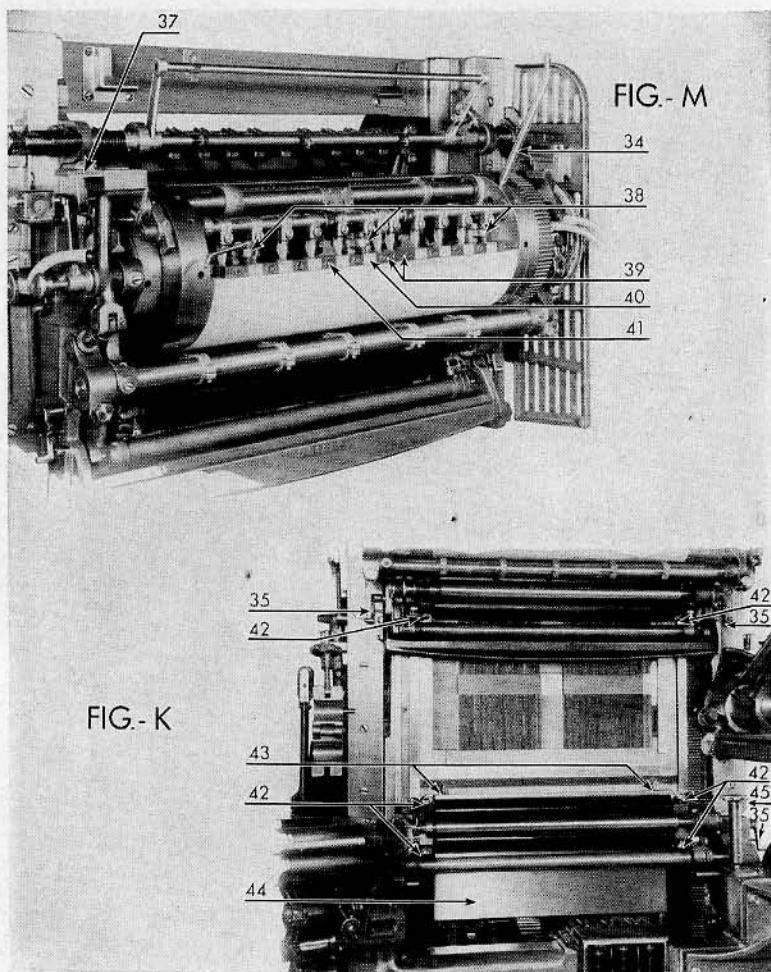

Fig. M. Cylinder of Vertical Press

- | | |
|------------------------------|-----------------------------|
| 34. Large pin wrench. | 39. Cylinder suction holes. |
| 37. Transfer table lock key. | 40. Gripper bar. |
| 38. Gripper bar screws. | 41. Cylinder grippers. |

Fig. K. Inking Mechanism of Vertical Press

- | | |
|--|--------------------------|
| 35. Distributor roller locking levers. | 44. Inking table. |
| 42. Roller adjusting screws. | 45. Fountain lock screw. |
| 43. Roller. | |

- c. Oil twice a day: bed gibs and slides, main driving shaft, pump, and cylinder bearings.
- d. Wipe off all excess oil.
- e. Run the press to makeready position and fill oil holes in the cylinder. Lock the cylinder and attach transfer table.
- f. Run the cylinder to bottom center. In this position all the oil holes can best be reached.

Procedure

1. Lock Up Form

- a. Note paper line marked on chase. This is where edge of the sheet will be, and is not adjustable.
- b. Note type line marked on chase. No type can extend below this line, for damage to the press and form will result.
- c. Note circles stamped on chase to show location of cylinder grippers sidewise only, and position form so that the circles are equally divided in relation to the sheet, being careful not to have a corner of the sheet come partly under the gripper.
- d. Underlay any cut that is not type high.
- e. Position type so sheet is approximately in center of chase sideways. Proceed to lock up form.

2. Place Form In Press

- a. Swing out feeder platform.
- b. Turn flywheel to left (as arrow indicates) until cylinder is at bottom of stroke. Unlock feeder lock. (Fig. A-18) and swing out feeder. (For heavy forms remove transfer table before placing form on press. This allows operator to get closer to bed of press).
- c. Place chase in bed, with use of large pin wrench to lift chase lock lever.

3. Repack Cylinder

- a. Turn press until cylinder is about one inch below top center, on down stroke. (Lock pin is opposite red mark on guard).
- b. Swing out cylinder end guard.

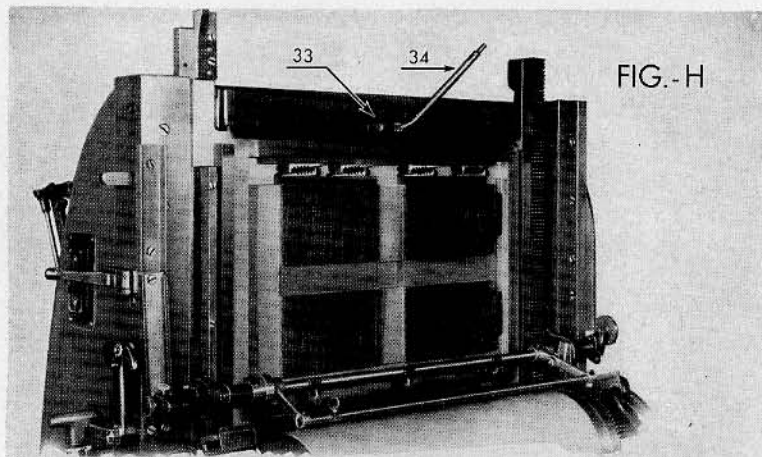

FIG. - J

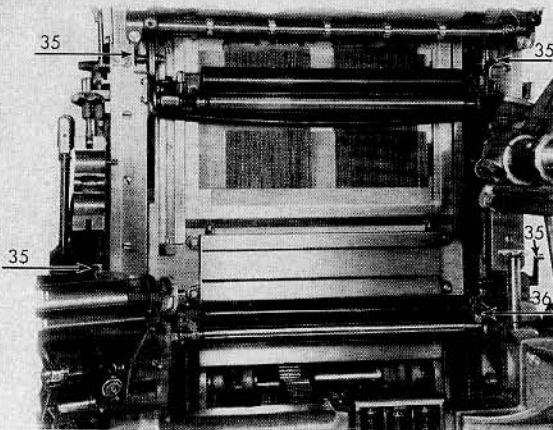

Fig. H. Chase in Bed of Vertical Press

33. Chase clamp. 34. Large pin wrench.

Fig. J. Rollers on Vertical Press

35. Distributor roller locking levers. 36. Roller key.

- c. Disengage cylinder safety pin.
- d. Turn cylinder with large pin wrench until it is in position to work on the gripper bar.
- e. Loosen, and back off the three screws until lower ends are flush with frame, and take out gripper bar.

NOTE—When gripper bar is out always examine to see if leather washers are in place. Always be sure trip holes in bar are free of paper lint.

- f. Cylinder is undercut .050.
- g. Pack cylinder with
 1. Three manila sheets (size 14x20 inches) .006 inch thick should cover the printing surface of the cylinder, allowing one inch for folding under gripper bar.
 2. Five sheets (14"x20") of S. and S. C. about .003 thick are placed next. No paste should be on any sheets.
 3. One manila top draw sheet .006-inch thick, 20 x 21 inches, the 21-inch edge allowing one inch to fold, and a tail to wrap around reel rod.
 4. Two filler sheets about .004-inch thick, cut 12½ x 20 inches, placed loosely in packing for makeready purposes.
 5. Hang the sheets on the cylinder where gripper bar clamps the packing, one at a time. Press the pins through the sheets, working from the center of the cylinder, until sheets are on.
 6. Replace gripper bar and tighten screws, clamping gripper bar and sheets in place. (Tighten center screw first).
 7. Continue turning cylinder in same direction, at the same time smoothing out the packing, until reel rod is in position for securing top draw sheet.
 8. Slip top draw sheet under reel rod, and fold and tighten with small pin wrench.
 9. Turn cylinder until cylinder safety pin snaps into lock.
 10. Close left cylinder end guard.

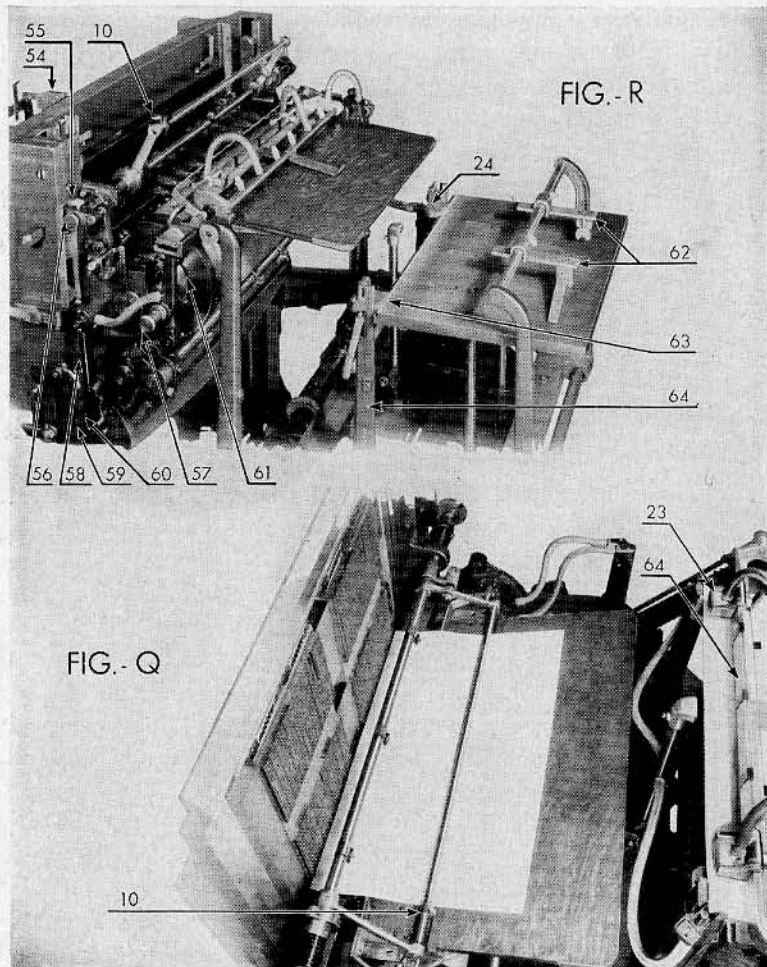

Fig. R. Feeding Mechanism of Vertical Press

- | | |
|---------------------------------|---------------------------------|
| 10. Side guide. | 59. Side guide cam screw. |
| 24. Front stock guides. | 60. Left side guide screw hole. |
| 54. Delivery wings. | 61. Safety pin lock collar. |
| 55. Side guide thumb screw. | 62. Rear stock guides. |
| 56. Side guide adjusting screw. | 63. Scale. |
| 57. Safety lock pin. | 64. Front pile guides. |
| 58. Side guide cam. | |

Fig. Q. Position for Setting Side Guide on Vertical Press

- | | |
|-----------------------------|----------------------|
| 10. Side guide. | 64. Separator frame. |
| 23. Separator shoe holders. | |

4. Set Rollers

- a. Swing out fountain by loosening fountain lock screw.
- b. Lock form rollers in position with two locking levers, one on each side of roller frames.
- c. Ink the press by distributing ink on lower vibrator roller, and allow to run for about a minute.
- d. Unlock both roller frames.
- e. Wash off ink table.
- f. Turn press until table is under distributor rollers.
- g. Lock roller frame, to contact ink table, swing down to inspect contact.
- h. Note width of roller impression on ink table.
- i. Reset if necessary to one pica width of line on ink table for the entire length of the roller.
- j. To back roller off, use small pin wrench; turn adjustment to right, for more contact turn to left.
- k. Drop distributors, move ink plate under form rollers and repeat process.
- l. The ductor roller needs no adjustment.

5. Set Ink Fountain

- a. Put ink in fountain.
- b. Run press until cylinder is at top center.
- c. Swing in fountain and lock.
- d. Adjust fountain screws by starting at the center and working toward the ends, to prevent buckling of the blade. Do not turn the screws to cut the ink clean from the roller—as this will injure the roller.
- e. Feeder side of fountain has a set wheel for regulating amount fountain roller will turn.
- f. Fountain crank will fit either end of roller.

6. Set Brush

- a. Have cylinder packed to proper height.
- b. Turn cylinder by hand until packing is under brush.
- c. Loosen small set screws on outside of cylinder frame.
- d. Place sheet between brush and cylinder.
- e. Move brush until tension is equal across the sheet.
- f. Tighten screws and move cylinder around to normal position.

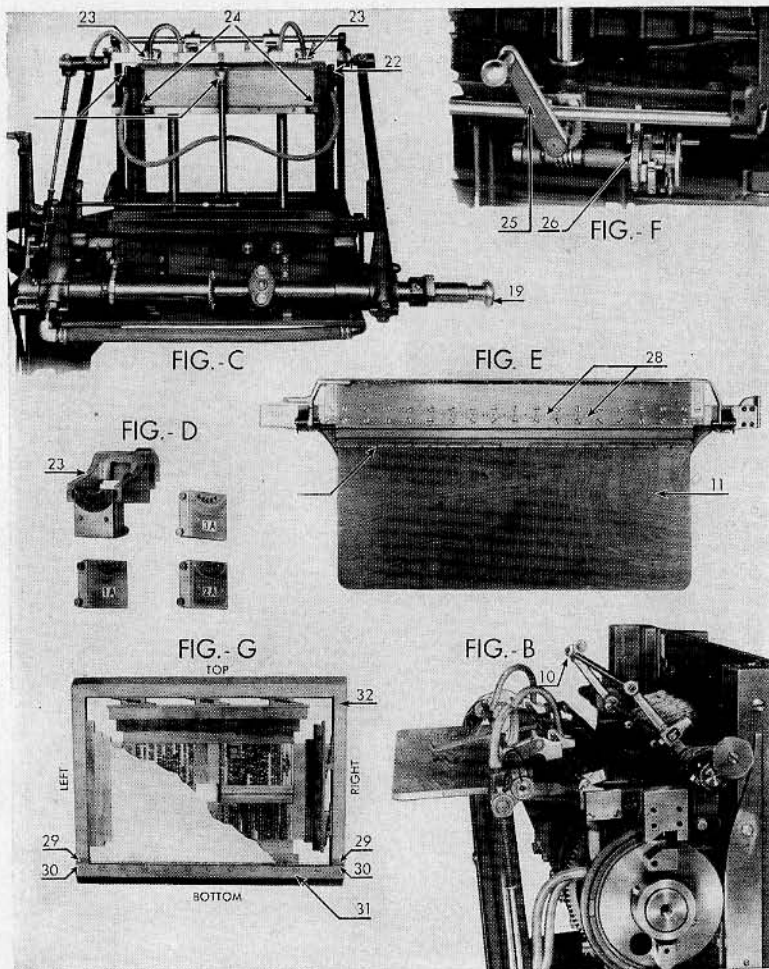

Fig. C. Feeding Mechanism of Vertical Press

- 22. Air jets.
- 23. Separator shoe holders.
- 24. Front stock guides.

Fig. D. Feeder Separator Shoes for Vertical Press

- 23. Separator shoe holders.

Fig. E. Transfer Table of Vertical Press

- 11. Transfer table.
- 27. Scale.
- 28. Suction holes.

7. To Position Sheet

- a. Replace the transfer table and lock it.
- b. To center form on sheet; measure length of form with a sheet the job is to be printed on. Fold the left over margin in half, then crease.
- c. Pass the sheet under side guide rod and bring the crease in line with the edge of form.
- d. Move the side guide over to edge of sheet and tighten.

NOTE—Side guide can be used on either side. To change side guide, run the cylinder to the top. Slide the side guide across the guide bar. Remove side guide cam screw and swing cam until opposite hole lines up. Insert screw in hole.

- e. Place sheet up to guides and print.

NOTE—Any adjustment up and down is made by moving the chase jacks at bottom of chase. A movement of three leads can be made each way.

- f. Examine Sheet for:
 1. Position.
 2. Impression.
 3. Correct position or impression as necessary.
 4. Get position O. K.

8. Set Feeder Pile

- a. Note the figure on the transfer table scale at the inside of the side guide.
- b. Set the corresponding feeder table pile guide so the zero line is at the same number.

Fig. F. Delivery Crank of Vertical Press

- 25. Delivery crank.
- 26. Delivery set wheel.

Fig. G. Lock-Up for Vertical Press

- 29. Type line.
- 30. Paper line.
- 31. Gripper marks.
- 32. Chase.

Fig. B. Gear Side of Cylinder

Showing cylinder stop mechanism (guard removed)

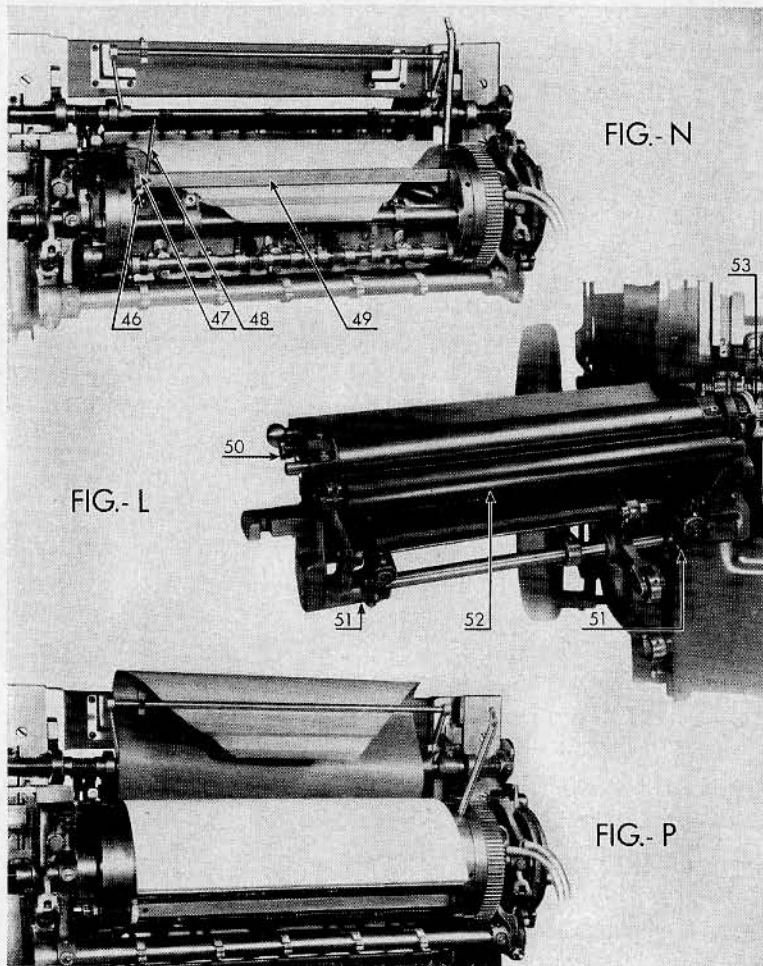

Fig. N. Securing Packing on Vertical Press

- | | |
|-----------------------|-----------------------|
| 46. Reel rod pawl. | 48. Small pin wrench. |
| 47. Reel rod ratchet. | 49. Reel rod. |

Fig. L. Fountain on Vertical Press

- | | |
|--------------------|-------------------------|
| 50. Grease cups. | 52. Ductor roller. |
| 51. Spring levers. | 53. Fountain set wheel. |

Fig. P. Makeready Position on Vertical Press

- c. Set the opposite pile guide to suit the sheet size. Allowing a lead clearance so stock pile does not bind.
- d. Load the feeder and run the pile up to within one half inch of the top of the front pile guides.
- e. Set the rear pile guides up to the back edge of stock pile.
- f. Set the separator shoes about one inch from the ends of the stock. (Always be sure shoe holders are locked on the separator frame).
No. 1A shoes for thin stock.
No. 2A shoes for medium stock.
Concave shoes for heavy stock.
No. 3A shoes for cardboard.
- g. With the cylinder down, swing feeder in and lock it.
- h. Spring clips on separator frame should be equally spaced between the separator shoes.
- i. Sheet guard should be on separator frame, especially for large sheet.
- j. Adjust the blast to wind five or six sheets from the top of pile.

9. Set Delivery

- a. Run one sheet through and stop the press just before the sheet is released by the delivery fingers.
- b. Position the side wings, release the sheet and move it up against the stop bar.
- c. Position the rear wings to back edge of sheet.
- d. Set the lowering ratchet according to the thickness of stock.

10. Makeready

- a. (See Makeready Manual)

11. Select proper pulley for speed wanted

- a. Smallest pulley, 2,500 an hour.
- b. Second pulley, 3,000 an hour.
- c. Third pulley, 3,500 an hour.
- d. Fourth pulley, 4,000 an hour.
- e. Largest pulley, 4,500 an hour.

12. Run

- a. Watch color.
- b. Observe operation of press.
- c. Check register.
- d. Watch for workups.
- e. Keep ink pushed down against fountain roller.
- f. See that rollers do not run hot.
- g. Watch for offset on printed sheets.

13. Numbering Machines

- a. Numbering machines will run in any position on the Vertical that they will run on any cylinder press. Do not place the plunger toward the dead line.

14. Grippers

- a. Stems have one side flattened. Round side is front guide and is indicated by an arrow stamped on head of the gripper.
- b. When sheets are cut straight, the round side of all grippers may be used as front guides by turning them with a screw driver so that all arrows point toward the sheet.
- c. If the stock is cut uneven, if the guides must be matched with that of any other press, or if a deckle-edge stock is used, any two or more of the grippers may be used, turning the rest of the grippers so that the arrows point toward the bed.

Hints for Operators

The following hints for operating the Miehle Vertical Printing press may be referred to when the pressman encounters the difficulties which may be laid to the following causes:

Feeder picks up two or more sheets:

1. Wrong separator shoes.
2. Insufficient blast.
3. Shoes not set correctly to side edge of sheet.
4. Pile table set too high or too low.
5. Stock sticks from
 - a. Offset.
 - b. Being cut with dull knife.
 - c. Static electricity.
6. Defective cut sheets are not up to front pile guides.

Shoes do not pick up sheets:

1. Wrong separator shoes selected.
2. Top of pile not level.
3. Pile guides set too tight.
4. Hair pin wires set too tight.
5. Sheets sticking from
 - a. Offset.
 - b. Dull knife.
 - c. Static electricity.
6. Hose on vacuum tube too short or too long causing play of shoe in holder.
7. Leaky or clogged vacuum.
8. Pile table too high or too low.
9. Leak in vacuum line.

Shoe picks up on one side only:

1. Sheets sticking from
 - a. Offset.
 - b. Dull knife.
 - c. Static electricity.
2. Pile guides not properly adjusted.
3. Hair pin wires too tight.
4. Incorrect shoe being used.

5. Shoe in wrong location.
6. Uneven pile.
7. Curled stock, causing shoe from sealing.
8. Shoe holder not locked on separator frame.
9. Leaky or clogged vacuum line.

Cylinder will not turn:

1. Sheet not fed up to cylinder grippers.
2. Cylinder hose reversed with hose to transfer table.
3. Sheets not sealing holes in gripper bar, caused by
 - a. Overpacked cylinder.
 - b. Curled sheets.
 - c. Bulky packing at gripper edge.
4. Leather washers out of gripper bar.
5. Gripper bar not sealed properly.
6. Diaphragm improperly adjusted.
7. Leaky or clogged vacuum.
8. Sheets not cut straight at gripper edge.
9. Diaphragm lever too tight.
10. Diaphragm clogged up with dirt.

Cylinder will not trip:

1. Gripper bar holes clogged up.
2. Diaphragm improperly adjusted.
3. Spring loose on diaphragm latch.
4. Thin porous stock, will not seal trip holes. (Release tension on diaphragm.)

Press will not trip or stop:

(Causing sheets to pile up on transfer table.)

1. Curly stock not sealing holes in transfer table.
2. Small sheet not covering holes in transfer table.
3. Automatic stop not working.
4. Leather washers in transfer table not sealing.
5. Automatic piston not operating freely, caused by
 - a. Too much oil.
 - b. Broken spring.
 - c. Vent hole clogged.
 - d. Gummy oil.

6. Reversal of hose to cylinder with hose to transfer table.
7. Leaky hose leading from table to auto stop cylinder.
8. Channel in transfer table clogged.

Shoes drag back sheet:

1. Clogged vacuum.
2. Kink in vacuum hose.
3. Separator shoe not free in holder.
4. No spring clips on separator frame.

Sheet bounces back from grippers:

1. Clogged vacuum line.
2. Front pile guide out of alignment.
3. Excessive speed.

Cylinder grippers do not hold sheet:

1. Overpacked cylinder.
2. Ink too tacky.
3. Burr or paper under gripper head.
4. Broken cylinder gripper springs.
5. Cylinder gripper binding in gripper bar.
6. Weak gripper springs.

Cylinder grippers tear sheet:

1. Burrs or paper under gripper head.
2. All grippers not lifting together.
3. Grippers not seated properly on bar.
4. Bent gripper heads.

Small sheet trouble:

1. Sheet not in center of transfer table.
2. Holes in transfer table not covered by sheet.
3. Pile guide out of adjustment.

Poor front register:

1. Overpacked cylinder.
2. Static electricity.
3. Transfer table lever springs broken.
4. Gripper edge of sheet not cut straight.
5. Front pile guides out of alignment.

6. Vacuum holes or channel in transfer table clogged.
7. Wavy sheet not sealing holes in transfer table.
8. Transportable sheet guard is binding sheet.
9. Sheet disturbed by rough edge to grippers.
10. Transfer table loose on supports.
11. Rear pile guide not close up to sheet.

Poor side register:

1. See causes under (1) poor front register.
2. Pile set wrongly in relation to side guide.
3. Side guide buckles sheet, caused by
 - a. Static electricity.
 - b. Transportable sheet guard is binding sheet.
 - c. Wet ink on back of sheet.
 - d. Burr on transfer table.
 - e. Stock cut roughly.
4. Side adjusting screw too tight.
5. Screws loose on
 - a. Side guide cam.
 - b. Micrometer adjustment locking screw.
 - c. Side guide.
6. Chase loose sideways on bed.

Wrinkles:

1. Too much impression.
2. Brush improperly set.
3. Wrinkled stock.